

Programming the world with Docker



Patrick Chanezon, Docker Inc.
@chanezon



My father's GE :-)

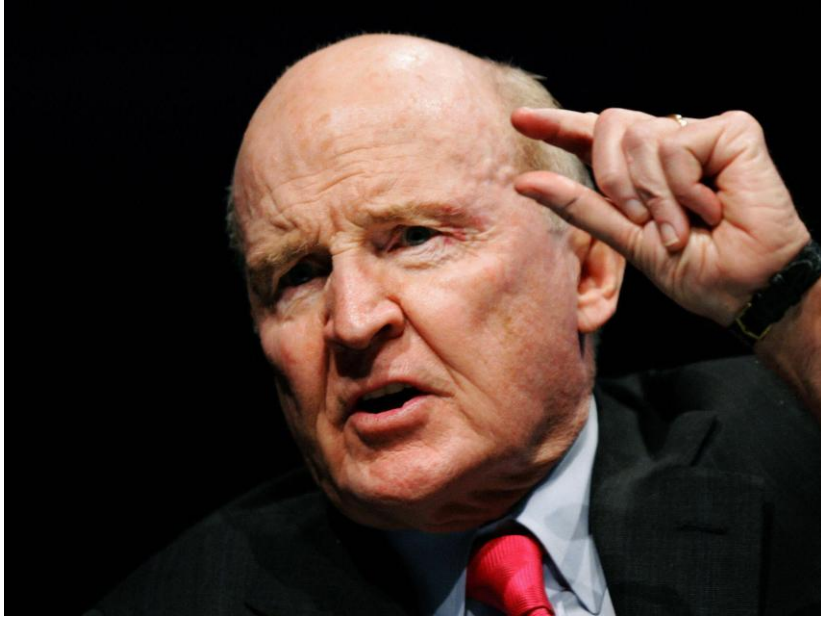

@chanezon

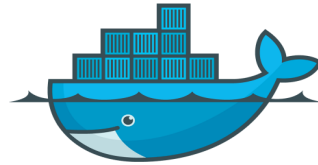

accenture



French

Polyglot

Platforms

Software Plumber

San Francisco

Developer Relations

1995



2015



Dreams of my childhood



Dreams of my childhood

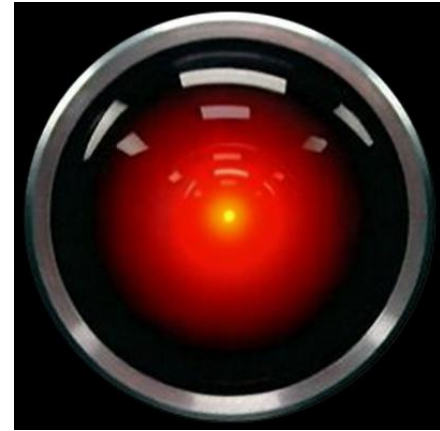
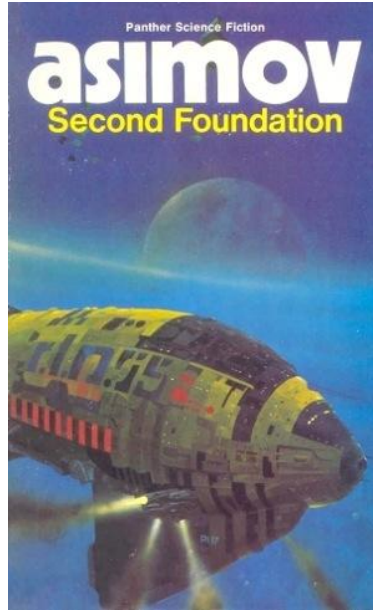
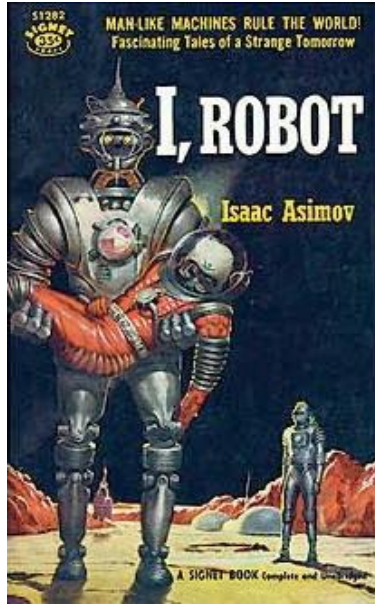

The Singularity... in a galaxy far far away

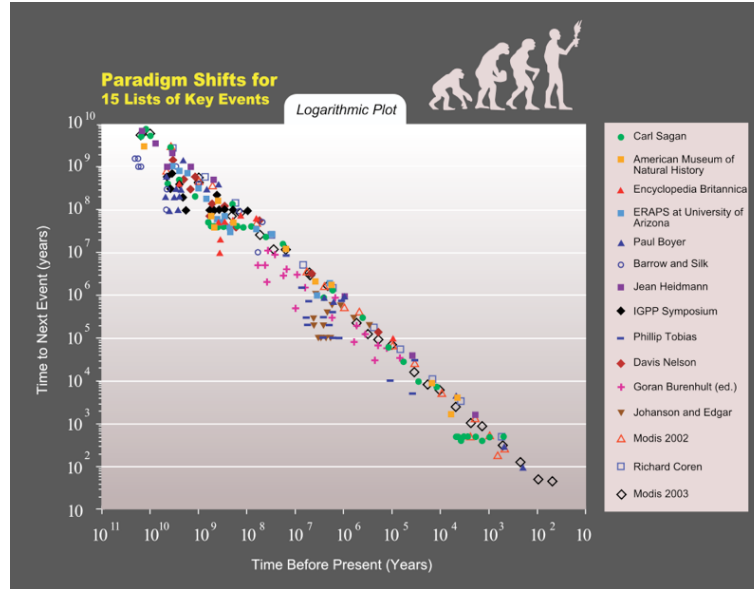

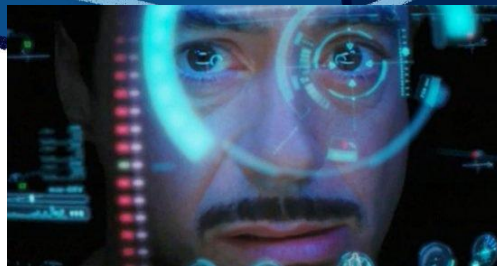
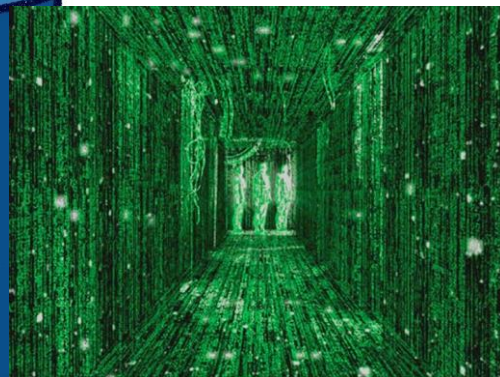

*“The future is already here —
it's just not very evenly
distributed”*

William Gibson, *Neuromancer*

Programming is changing the world

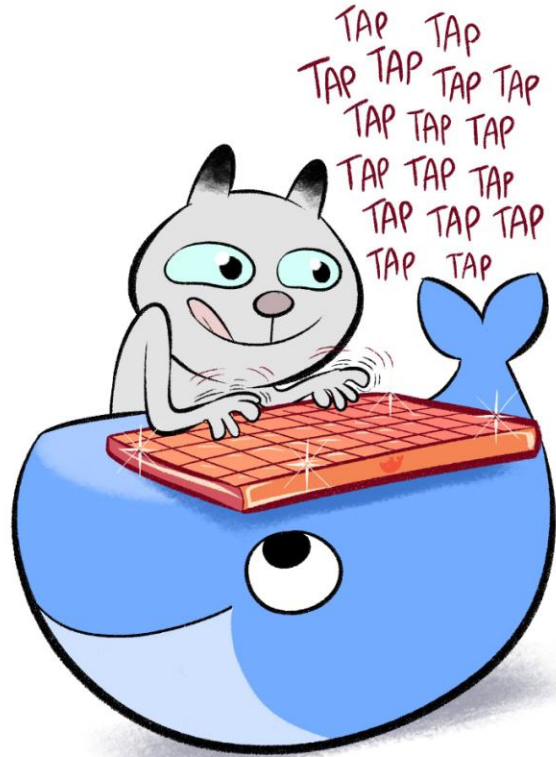

Platforms & Networks

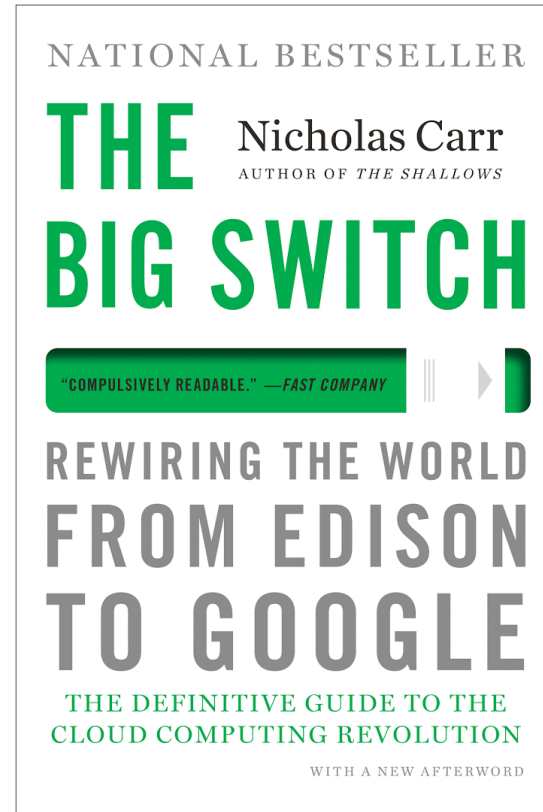
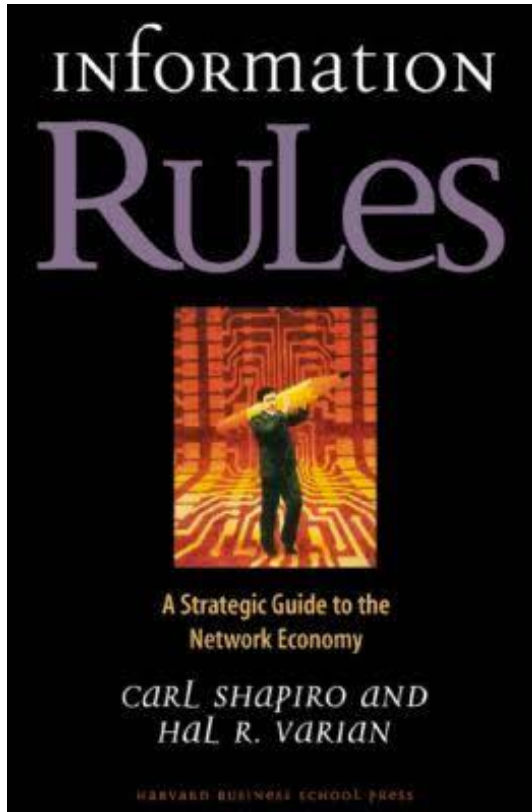

Platforms & Networks

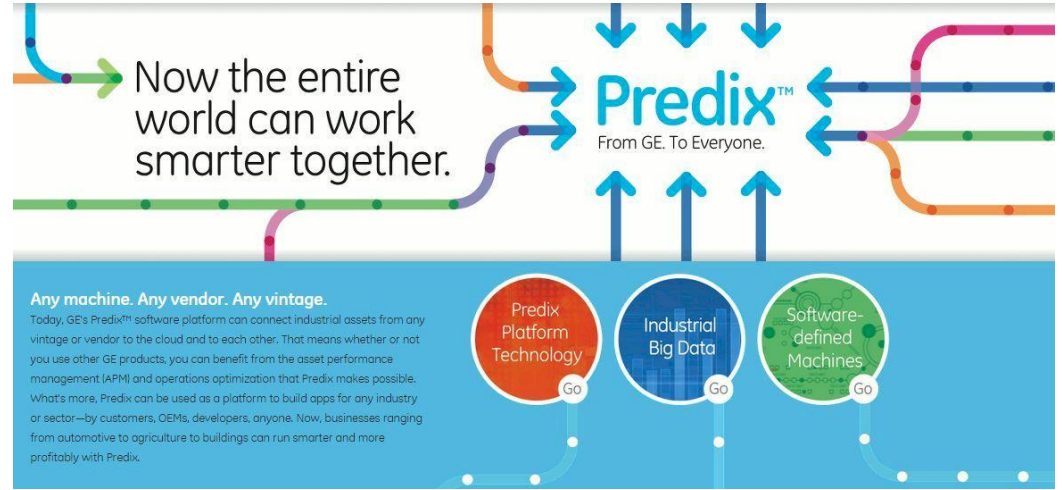
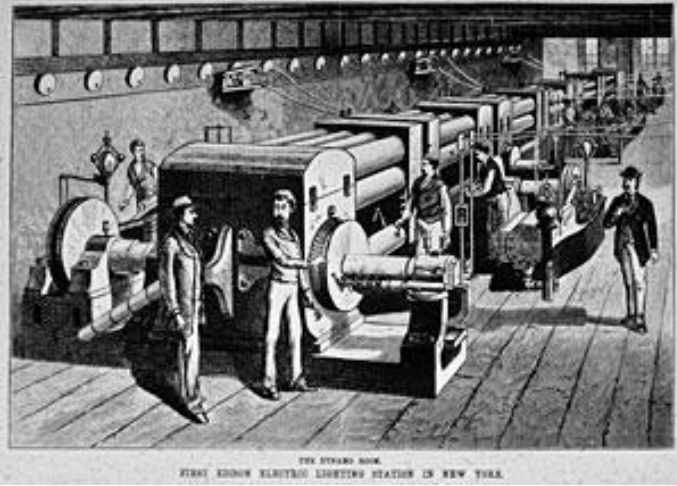

The world needs
tools of mass innovation

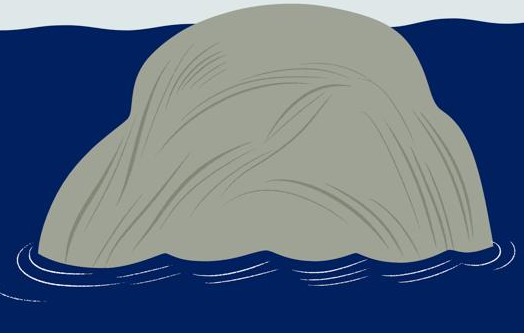

Programmers

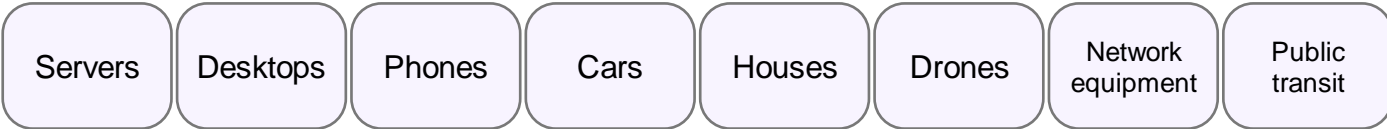
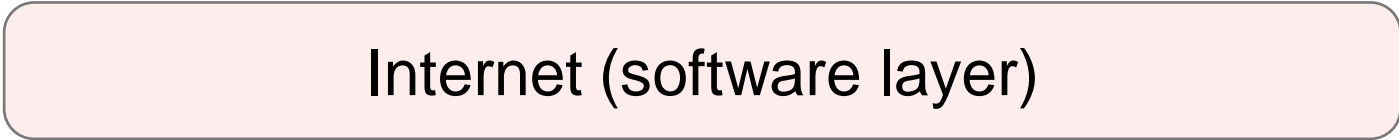
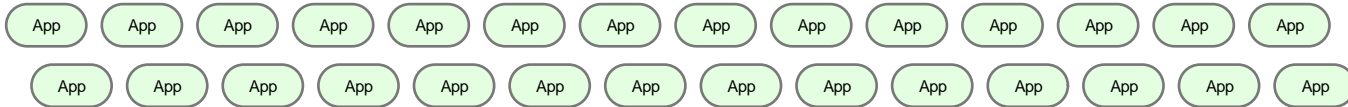

Programmers



a software layer to program the internet

Internet (hardware layer)

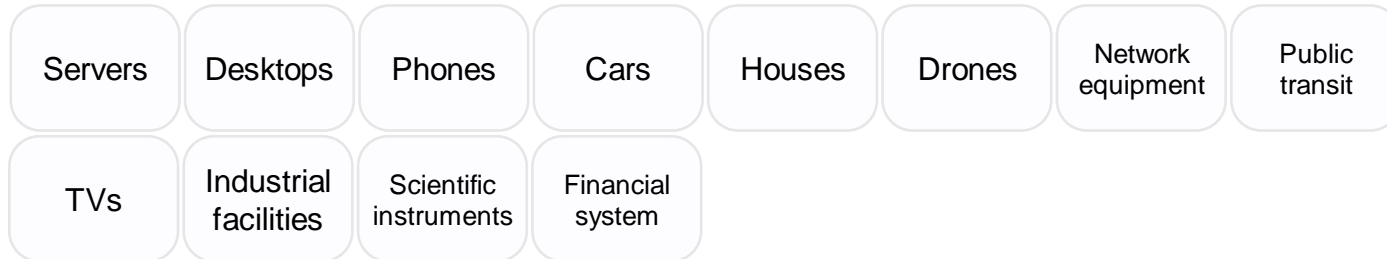

Ops

Devops

Developers

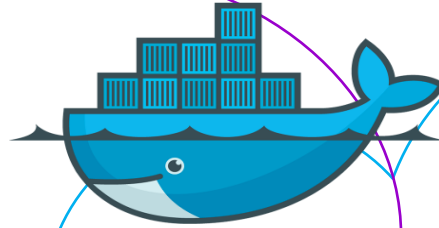

vmware®

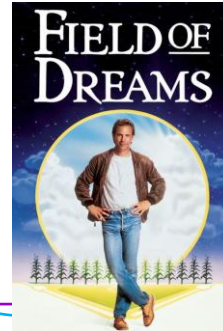

Private

Hybrid

Public

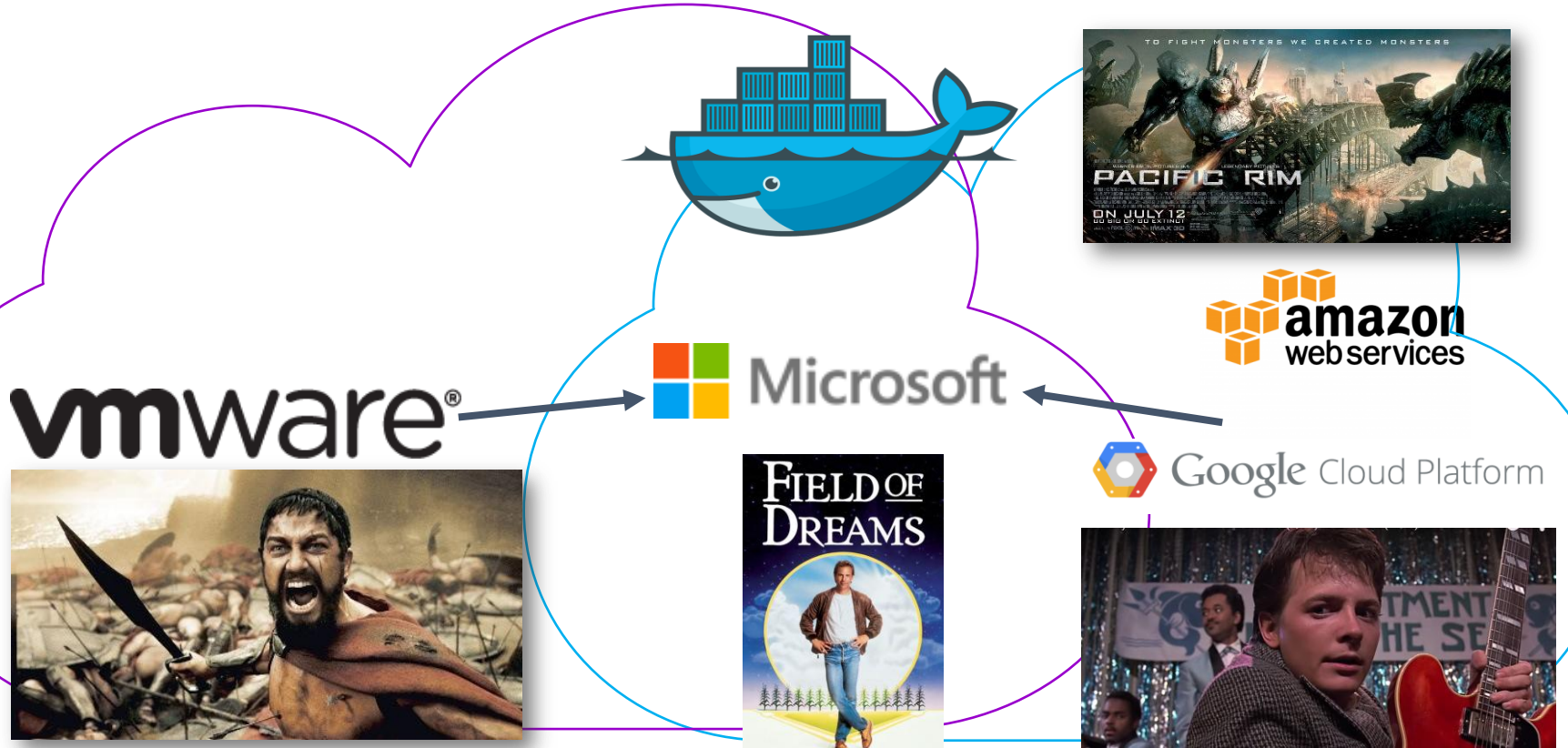

Lessons to build your cloud



Research Papers



Hybrid Cloud



2 Pizza teams



Open Source



Portability



Google: the story of Urs Hölzle's Flashlight



Firesword, 3000 Lumens

Google research papers

- Horizontal scalability 2004: Map/Reduce (Hadoop)
- NoSQL 2006: Bigtable (Mongo, Cassandra, HBase, Riak)
- Real Time analytics 2010: Dremel, BigQuery (Impala)
- Horizontally Scalable SQL 2012: Spanner, F1 / Amazon Redshift
- Building High-level Features Using Large Scale Unsupervised Learning - 2012

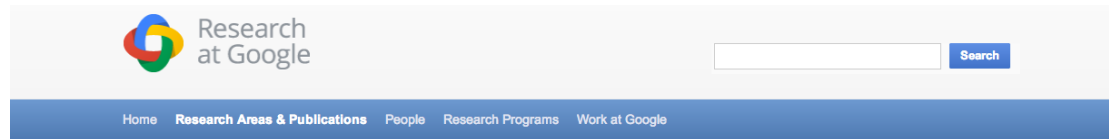

Research Areas & Publications

Publishing at Google

Google publishes hundreds of research papers each year. Publishing is important to us: it

Algorithms and Theory

Artificial Intelligence and
Machine Learning

Data Management



Linux Container Ecosystem

Plugins

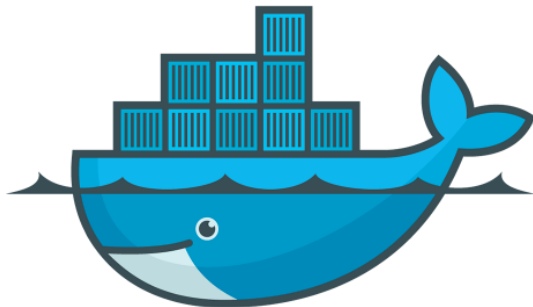
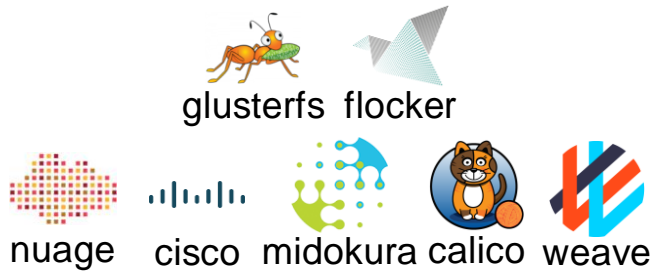

Orchestration



OS



Cloud



Agility





Agile methodologies (circa 1999)

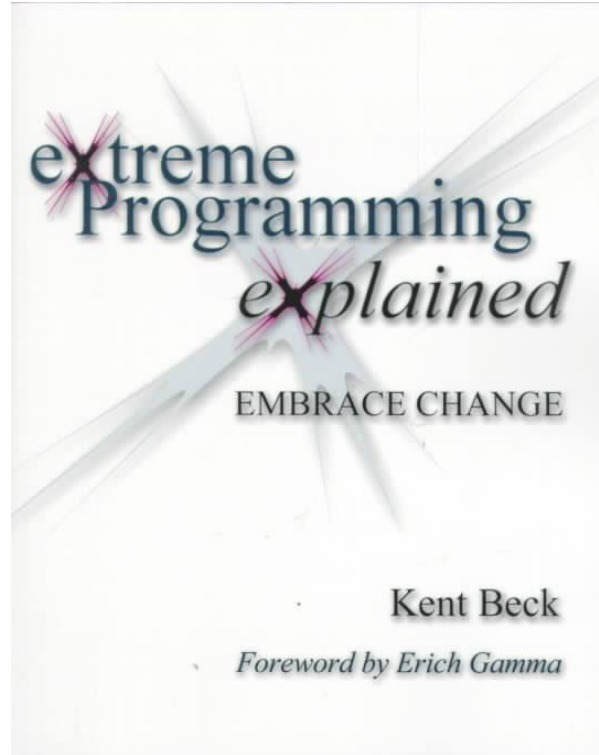



Low MTBIAMSH

MTBIAMSH (Mean Time Between Idea And Making Stuff Happen)



Agility == \$\$\$

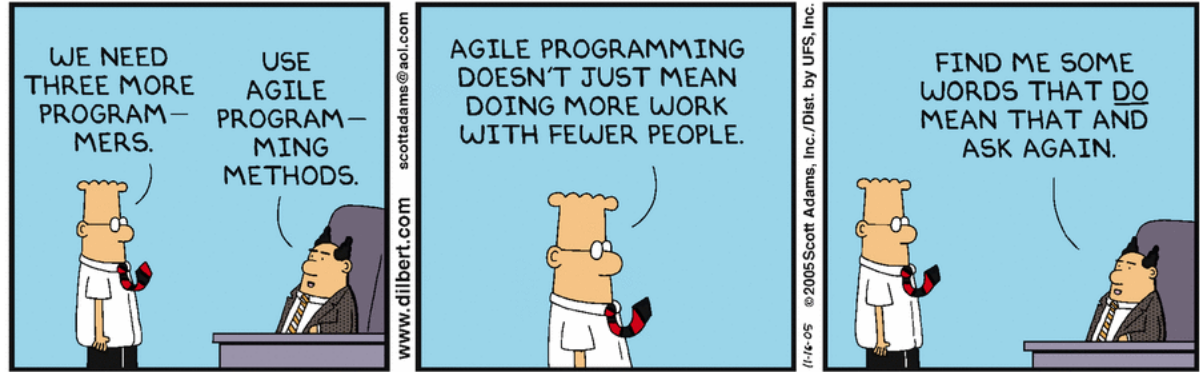
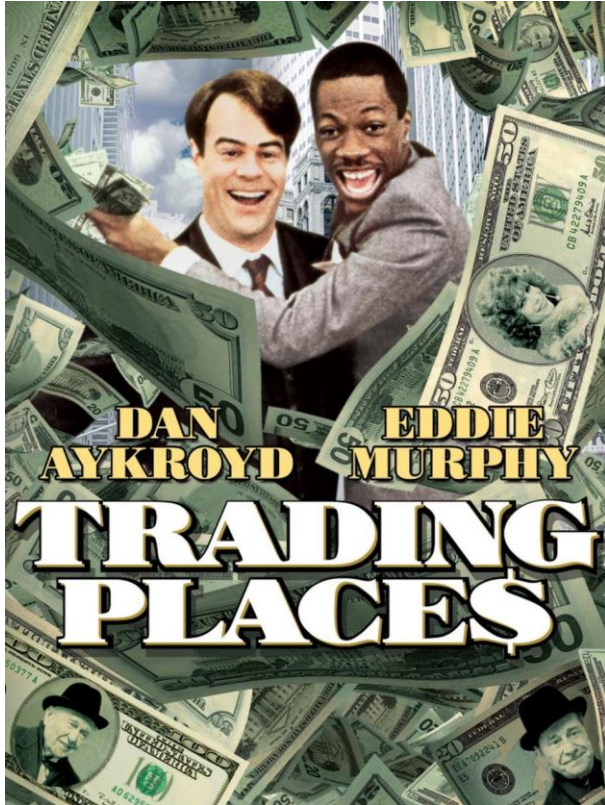

Devops

Mainframe

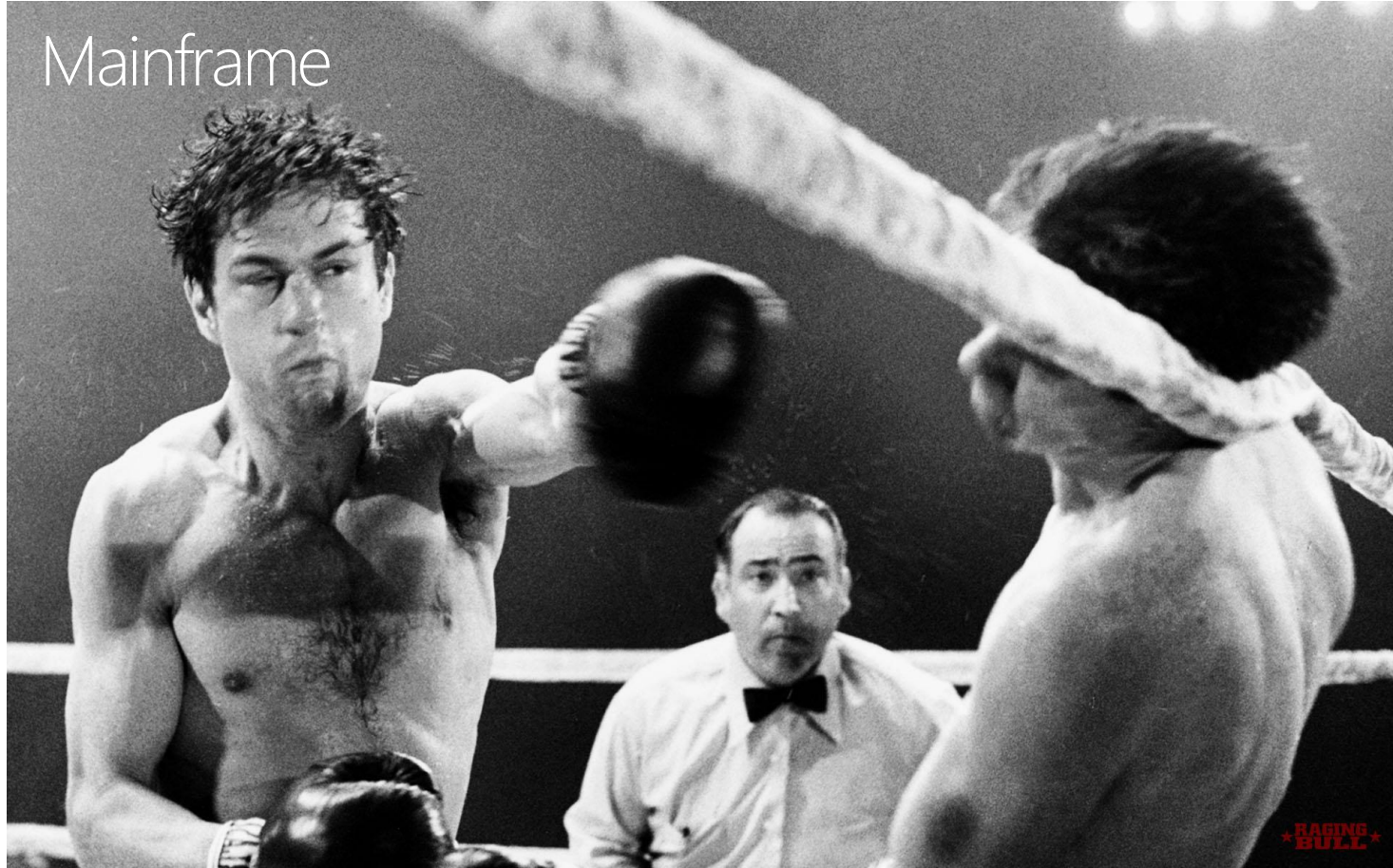

Client-Server



Web



Cloud - Devops



Devops

- Cultural movement
- Inspired by agile methods
- People, Processes & Tools
- Continuous delivery
- Infrastructure as code
- Cross silo collaboration
- Small iterations
- Feedback loop, measurement

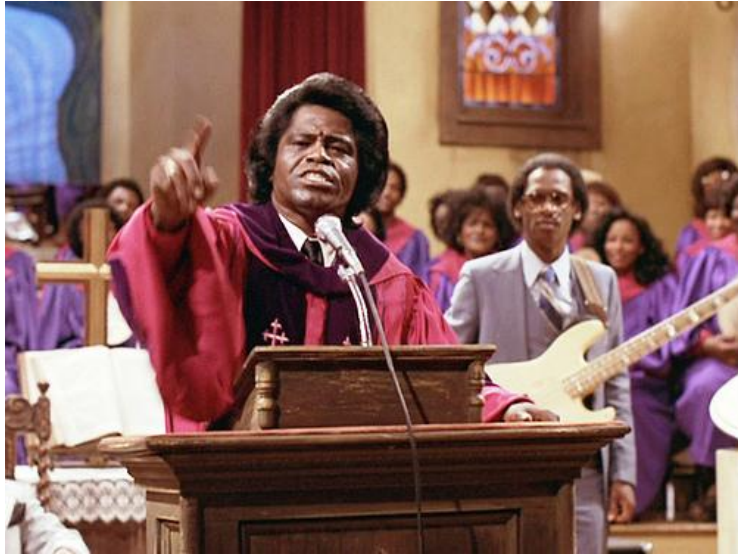

Image from Patrick Debois

<http://www.slideshare.net/jedi4ever/devops-the-war-is-over-if-you-want-it>

<http://www.slideshare.net/jedi4ever/devopsdays-downundervfinal>

Devops: singing Kumbaya?



Server/Sysadmin

1999: 5(Windows) - 50 (Linux)

2015: 10k-20k

x2000

People, Processes, Products

Continuous Delivery in a large Enterprise – Transforming Enterprise IT

ING has been re-organizing for agility at scale on many levels

Year	Key Event / Milestone
2008	Start of our own back-ends Engineering culture May 2008 (single IT)
2008	The end of change
2008	Start of mobile app development
2009	Start full automation of IT processes Continuous delivery End of single May 2009
2010	Start of DevOps Discussion - who owns production
2011	Clear demarcation responsibilities: SAs and ops

thinkforward | ING

dockercon14 eu
December 4-5, 2014 - Amsterdam

deployment time: 9 months -> 15 min
1500 deployments/week

Henk Kolk, ING, DockerCon EU 2014

<https://blog.docker.com/2014/12/dockercon-europe-keynote-continuous-delivery-in-the-enterprise-by-henk-kolk-ing/>

Docker

Isolation using Linux kernel features

namespaces

& pid

& mnt

& net

& uts

& ipc

& user

cgroups

& memory

& cpu

& blkio

& devices

Image layers

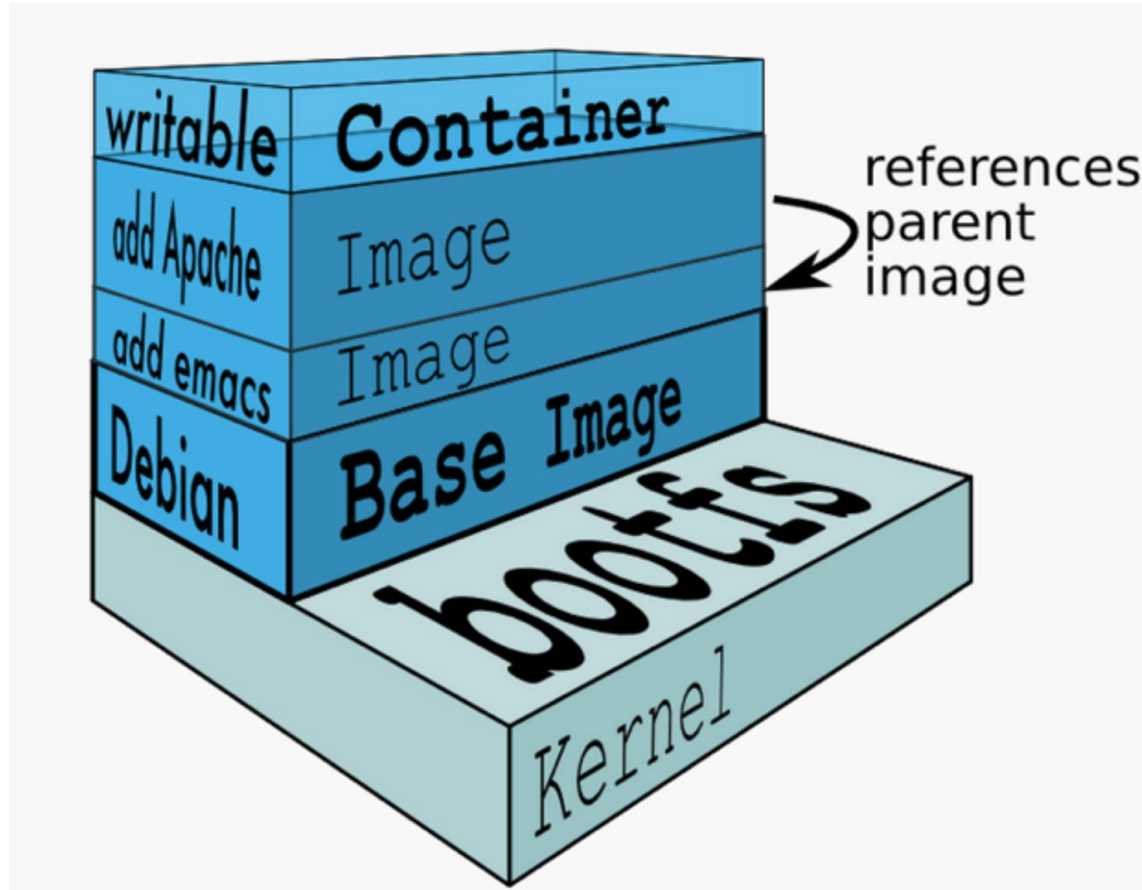

1.

Developer experience

Let's eliminate friction in the development cycle

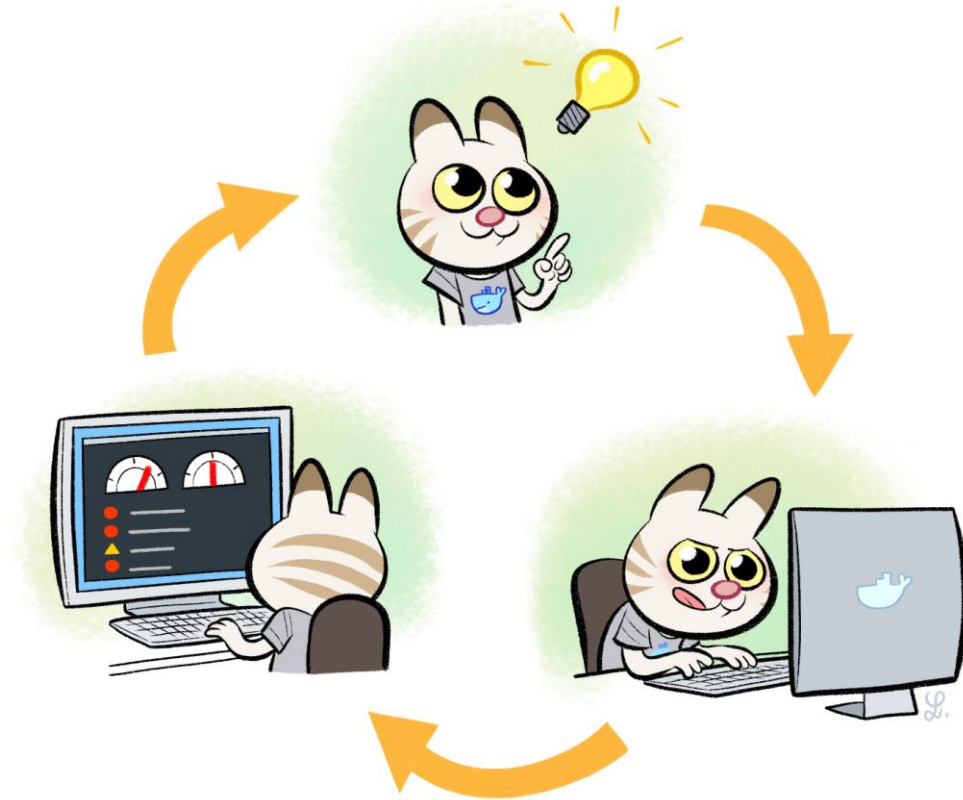

The best tools...

The best tools...

1. Get out of the way



The best tools...

1. Get out of the way
2. Adapt to you



The best tools...

1. Get out of the way
2. Adapt to you
3. Make the powerful simple

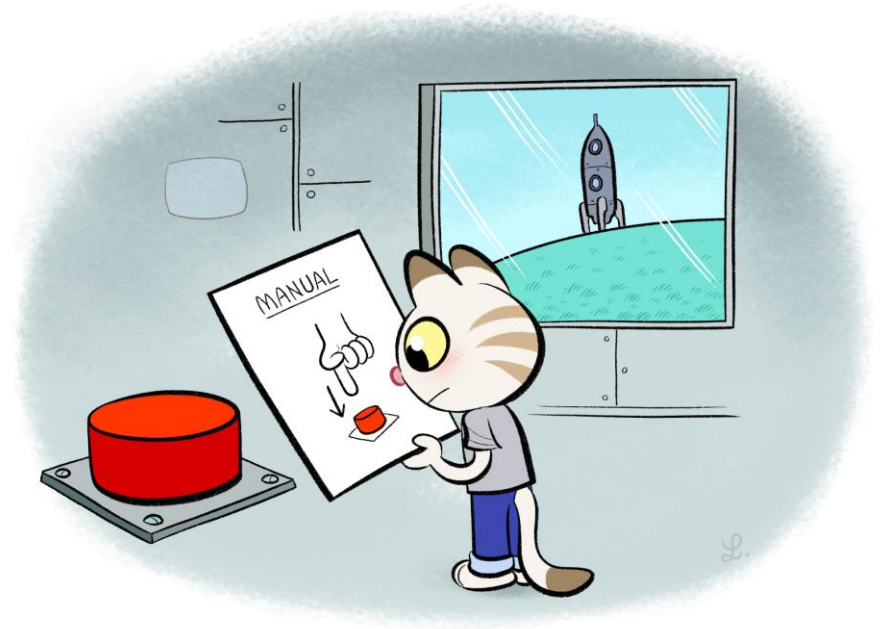

BETA



Docker for Mac



Docker for Windows

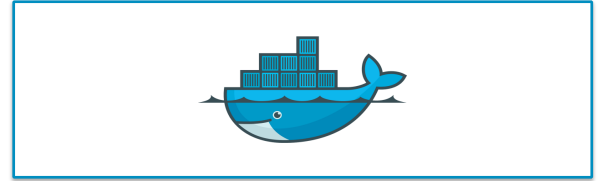
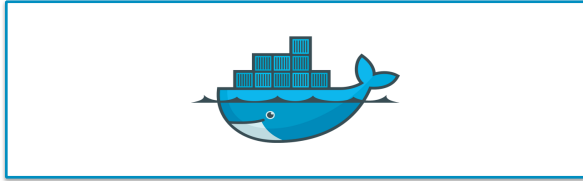

Making things easy is really hard.

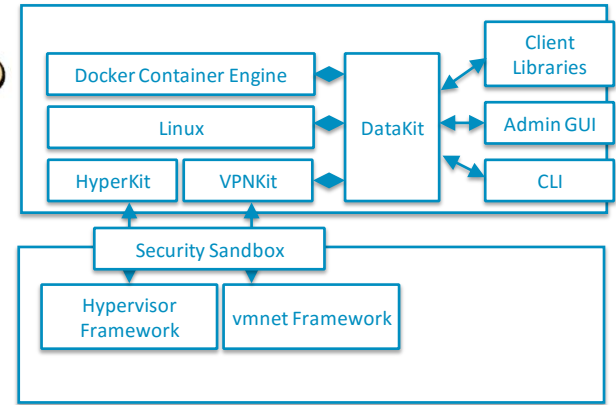
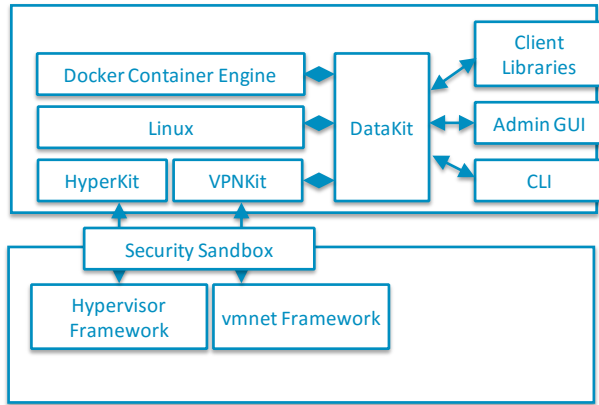

Making things easy takes a special team.



Making things easy is really hard.

1. Find the best systems engineers.

Docker Acquires Unikernel to Improve Container App Deployments

By Sean Michael Kerner | Posted 2016-01-21  Print

 Tweet  LinkedIn 46  Like 17  Share 4  Share 63  Email

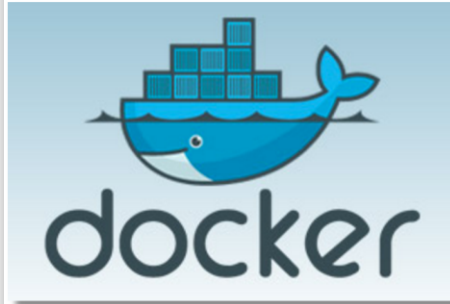

Solomon Hykes, Docker founder, explains and the concept of purpose-built microkernel improve the future of computing.

Docker Inc. today announced the acquisition of Unikernel Systems in a deal that aligns the emerging purpose-built system development with Linux and Windows containers. Financial terms of the deal are not being published.

"Just like we've seen a spectrum of applications deployed across virtual machines, Linux and Windows containers, we expect the spectrum of microkernels," Solomon Hykes, founder of Docker, told *eWEEK*.

The company has made several acquisitions in recent years, each one adding a new element to its container ecosystem.

The company has made several acquisitions in recent years, each one adding a new element to its container ecosystem.

Unikernels

Isolation & specialisation with unikernels

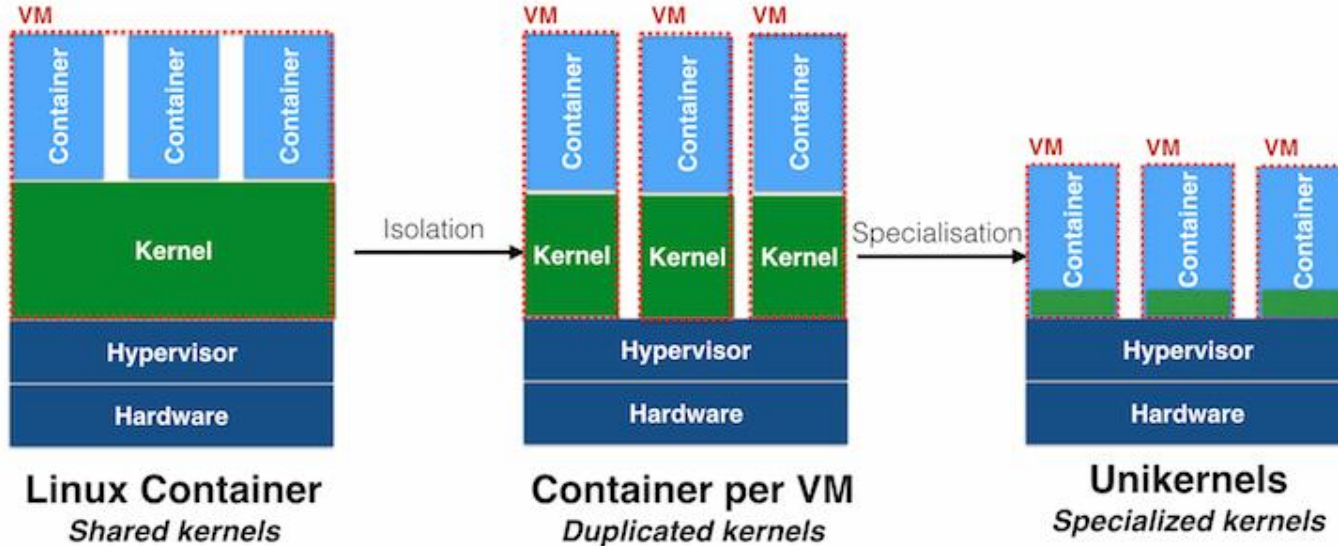

<http://unikernel.org/>

Making things easy is really hard.

1. Find the best systems engineers.

2. Bring designers back from the future.

Docker Acquires Unikernel to Improve Container App Deployments

By Sean Michael Kerner | Posted 2016-01-21 [Print](#)

[Tweet](#) [LinkedIn](#) 46 [Like](#) 17 [Share](#) 4 [Share](#) 63 [Email](#)

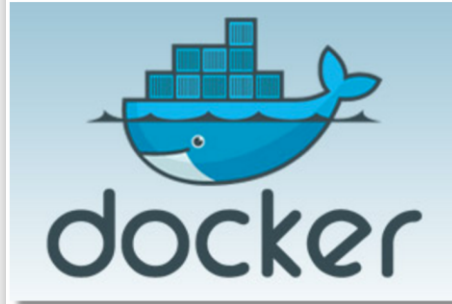

Solomon Hykes, Docker founder, explains and the concept of purpose-built microkernel improve the future of computing.

Docker Inc. today announced the acquisition of Unikernel Systems in a deal that aligns the emerging purpose-built system development with Linux and Windows containers. Financial terms of the deal are not being published.

"Just like we've seen a spectrum of applications deployed across virtual machines, Linux and Windows containers, we expect the specification of microkernels," Solomon Hykes, founder of Docker, told *eWEEK*.

The company has made several acquisitions in recent years, each one adding a new element



 **Kelsey Hightower**
@kelseyhightower

 Following

Docker hit a home run with Docker for Mac.
Smooth install process and it just works.

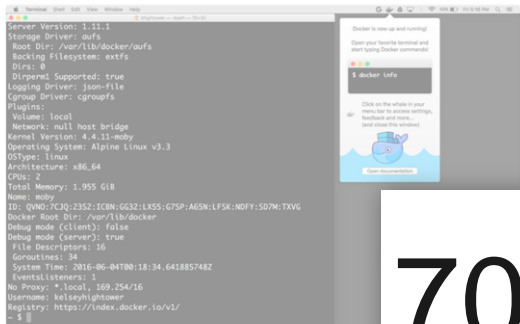

RETWEETS 94 LIKES 185

4:21 PM - 3 Jun 2016

 **Michael Schuett**
@michaels1990

 Following

#docker for mac is 100100100100100 better than
docker machine. Getting closer to developers
actually having the same environment.

 **Joshua Tessier**
@joshuatessier

 Following

The @Docker for Mac beta is such a huge
quality of life improvement. Not only does it
sidestep ye olde inotify issues, but it's so fast.

RETWEETS 5 LIKES 9

2:38 AM - 7 May 2016

 **@theobserving**

 Following

Installing the @docker for mac beta was smooth,
very smooth. #GoodVibes

 **fidel karsto**
@fidel_karsto

 Following

Happily beta testing docker for Mac - it solves a
lot of issues already. Finally docker on OS X feels

70,000 beta testers

Thank you!

 **Gypsy**
/psy

 Following

docker beta for OSX. And once again,
I am dumbfounded by @Docker awesomeness.
The very definition of genius! #docker #osx

RETWEETS 2 LIKES 3

8:35 PM - 4 May 2016



 **lan Turgeon**
@lturgeon

 Following

The @docker for Mac beta looks great guys.
Migration was flawless. Mounted disc is slow for
now, but very promising stuff.

LIKES 3

5:43 PM - 4 May 2016

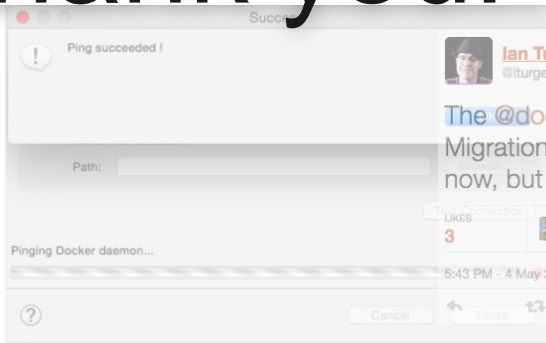

TLDR: just open it already!



Kelly Sommers
@kellabyte



Following

I wish Docker for Mac was a public beta. I have to keep asking people to apply to try my code.

RETWEETS

5

LIKES

17



10:21 AM - 15 Jun 2016



5

17



while True:
@binarydud



Follow

hoping to get into the @docker for mac beta soon. My vpn and docker-machine don't get along.

LIKES

2



5:49 AM - 3 May 2016



5

2



Geoffrey Gieseemann
@ggieseemann



Follow

Anyone know a faster way to get into the @docker for Mac beta? #lazyweb

5:45 AM - 26 May 2016



Joseph Earl
@josephearl



Follow

Anyone got a spare invite to the Docker for Mac beta? Still waiting to hear back :(

4:19 AM - 10 May 2016



Docker for Mac & Windows Public Beta

docker.com/getdocker



2.

Orchestration



The problem with orchestration:



The tech is solved, but only experts can use it.

Orchestration for non-experts:



Hire an army of experts...



or lock yourself in

Introducing the best way to orchestrate Docker: Docker.

Docker 1.12: now with orchestration built-in.

Docker 1.12: now with orchestration built-in.

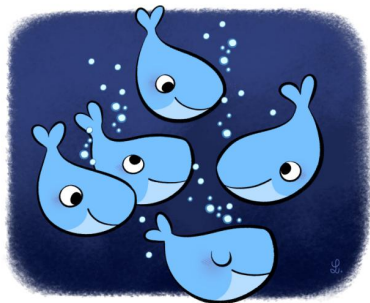

Swarm mode

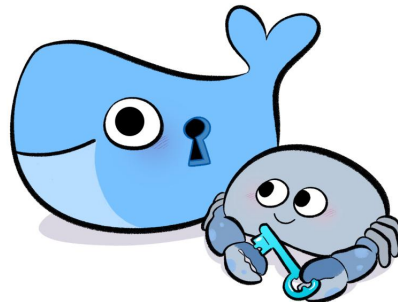

Cryptographic node identity



Service API

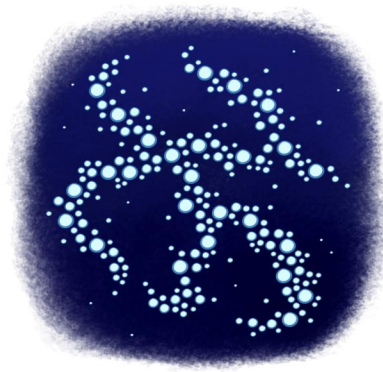

Built-in routing mesh

Swarm mode

Combine your engines in swarms of any scale

Self-organizing, self-healing

No external data store required

No single points of failure

Infrastructure-agnostic topology

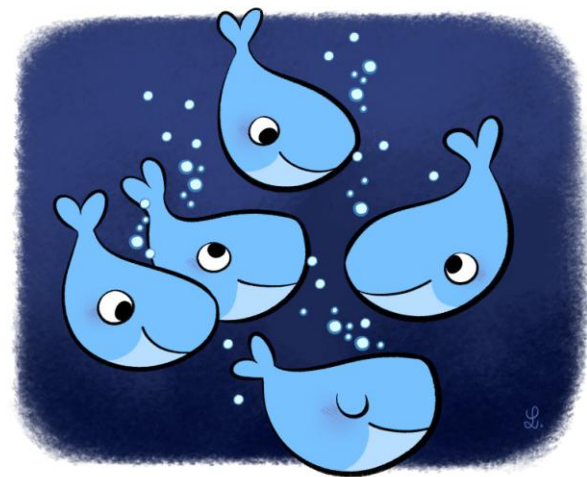

Cryptographic node identity

Government-grade security by default

End-to-end TLS

Built-in government-grade PKI

Automated key rotation

Revoke any node at any time

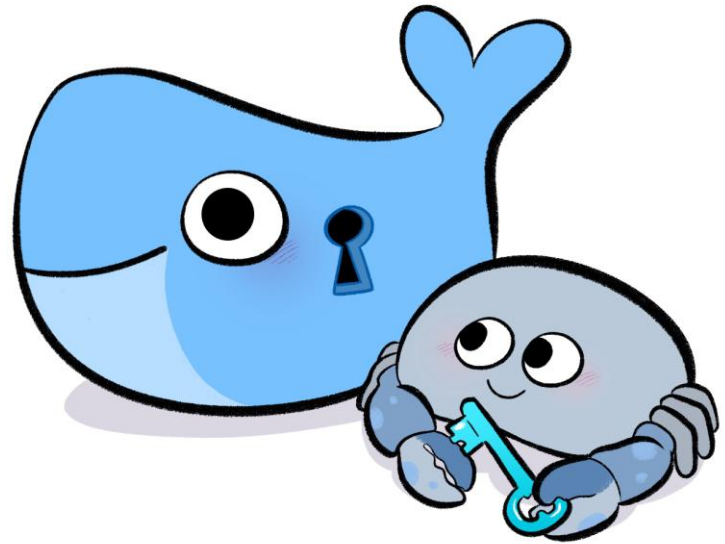

Docker Service API

Desired state reconciliation

Scaling

Rolling updates

Advanced scheduling

Application-specified health checks

Rescheduling on node failure



Built-in Routing Mesh

Swarm-wide overlay networking

Container-native load-balancing

DNS-based service discovery

No separate cluster to setup

Works with your existing load-balancers

Rock-solid kernel-only data path with IPVS

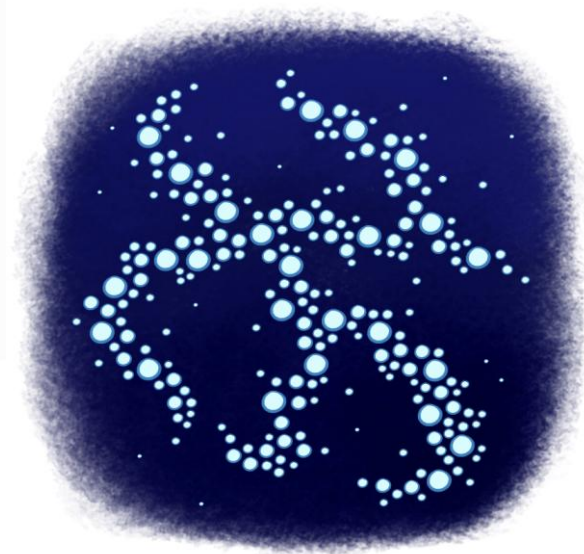

Docker 1.12: now with orchestration built-in.

Docker-native experience

No external dependencies

No single point of failure

Secure by default

Works with your infrastructure

Reverse compatible



Using the beta? You already have 1.12 installed.



```
> docker swarm init  
> docker service create
```



3.

Ops experience

BETA



Docker for AWS



Docker for Azure

beta.docker.com

beta.docker.com



Deep integration with native load-balancers, templates, SSH keys, ACLs, scaling groups, firewall rules...

Nobody cares about containers

Nobody cares about containers

It's the application that matters!

Distributed Application Bundle

A portable format for multi-container applications

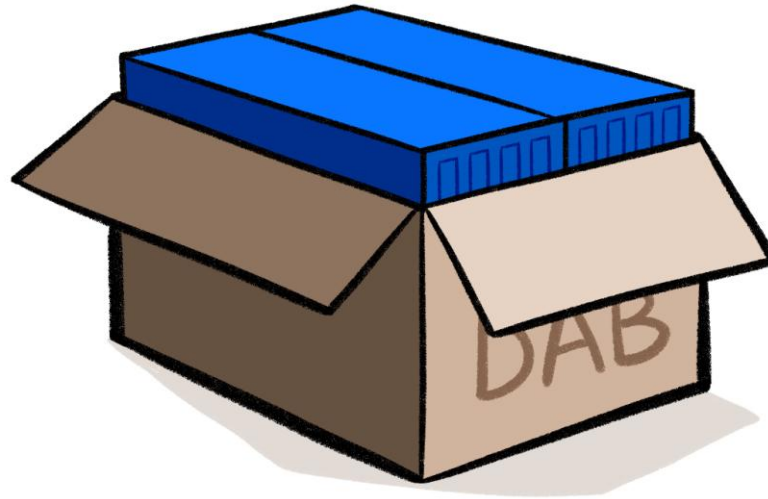

www.docker.com/dab

Docker CaaS

XaaS Pyramid

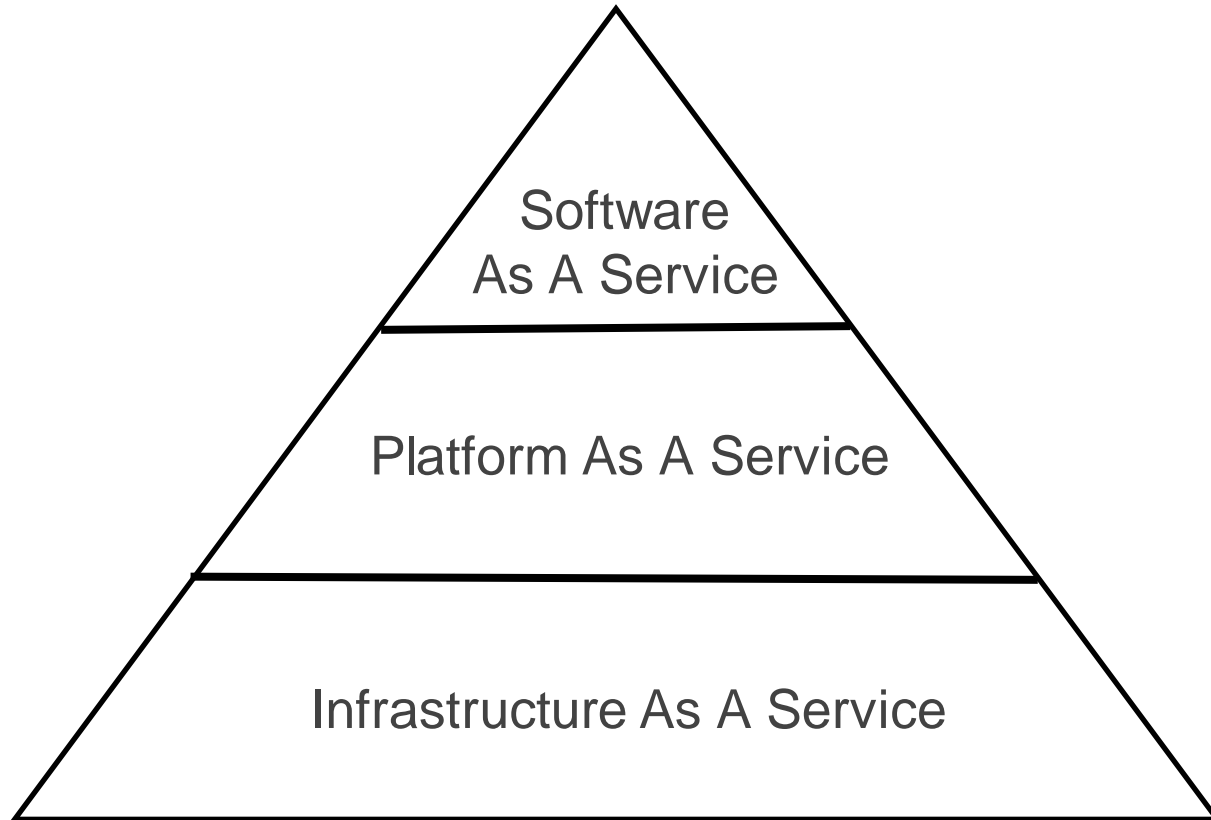

Cloud Computing Defined



6:55 / 49:19



GDD-BR 2010 [1B] What's New in Google App Engine and GAE for Business

agenda

- cloud foundry – PaaS
- sample app:
 - polyglot in action
 - node
 - redis
 - json
 - ruby
 - html5
 - jQuery
 - multi-tier
 - horizontally scalable
 - vmc manifest
 - etc.

developer perspective v2.0



1:02 / 40:04



Developer Productivity with Cloud Foundry - Tokyo Open Tour

Goldilocks and the 3 XaaS



IaaS
Too low



PaaS
Too high

CaaS
Just right

Goldilocks and the 3 XaaS

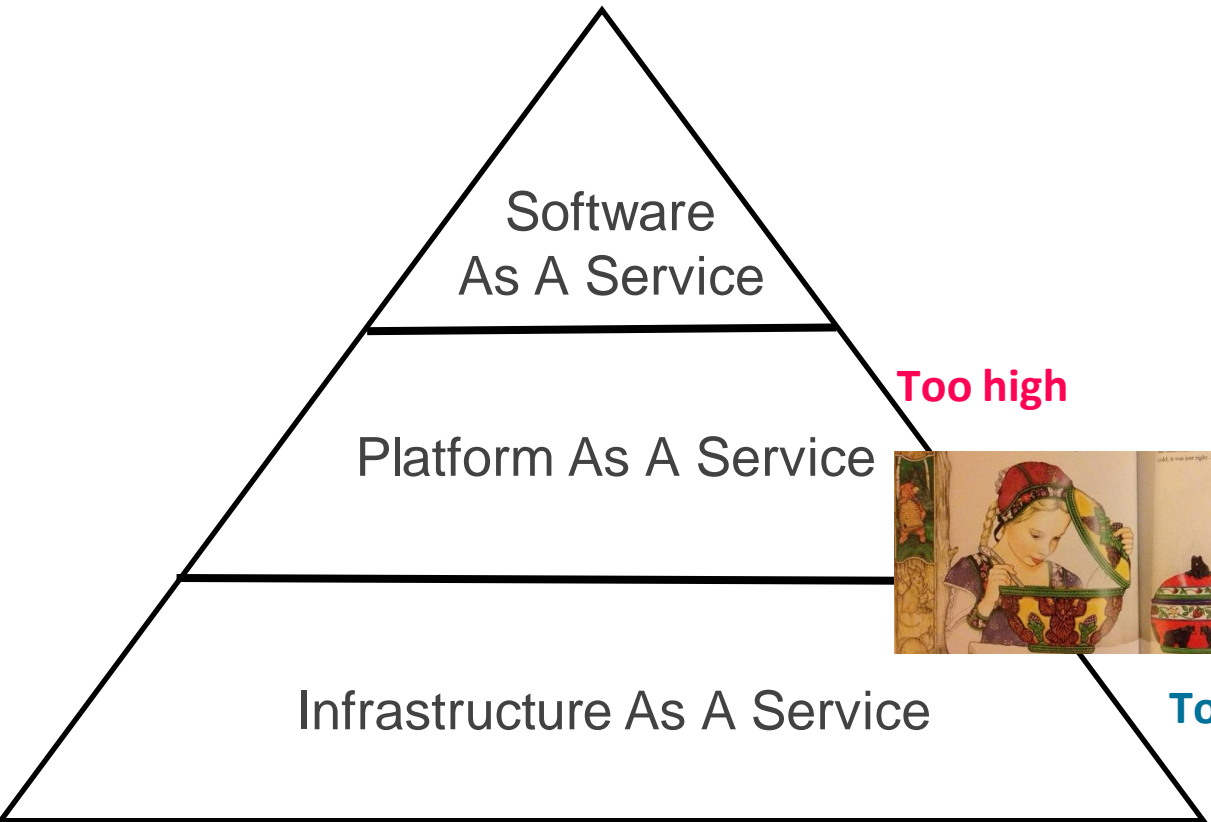

Too high

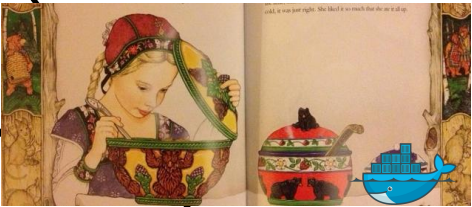

Container As A Service

Just right

Too low

Example

- “- When do you guys support FORTRAN?”
- Sorry it's not supported by Cloud Foundry yet”

The Way Forward Requires



Agility

+



Portability

+



Control

The Global Enterprise Supply Chain

Containerization: standard containers on a standardized container engine

Orchestration: build and deploy complex systems easily

Enterprise: Enable delivery and time to value across a large, complex, rapidly evolving enterprise

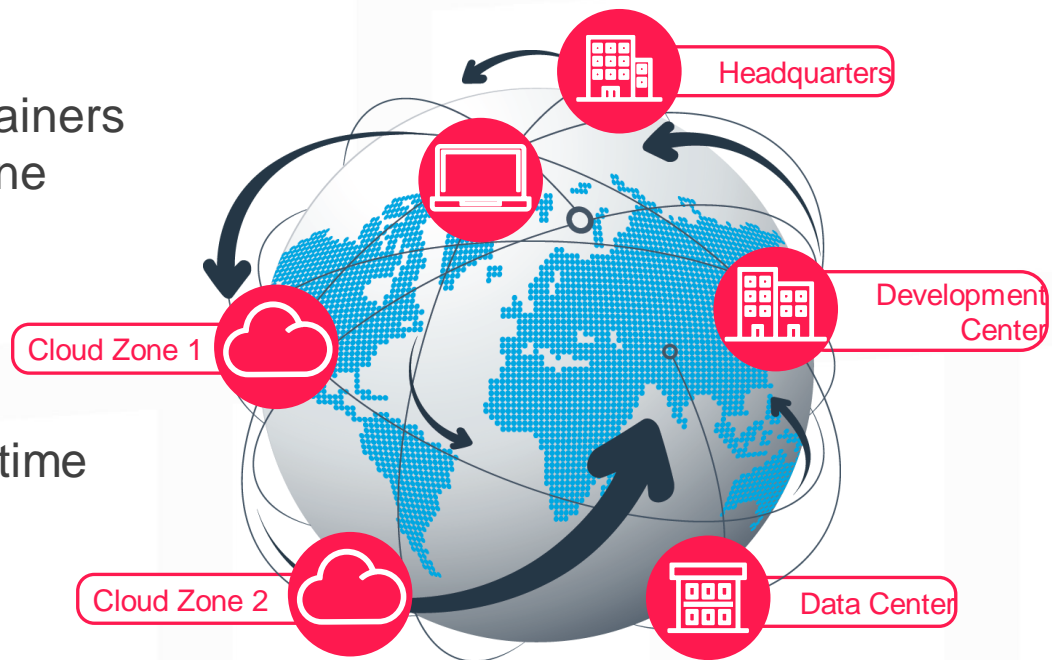

Containers as a Service (CaaS)

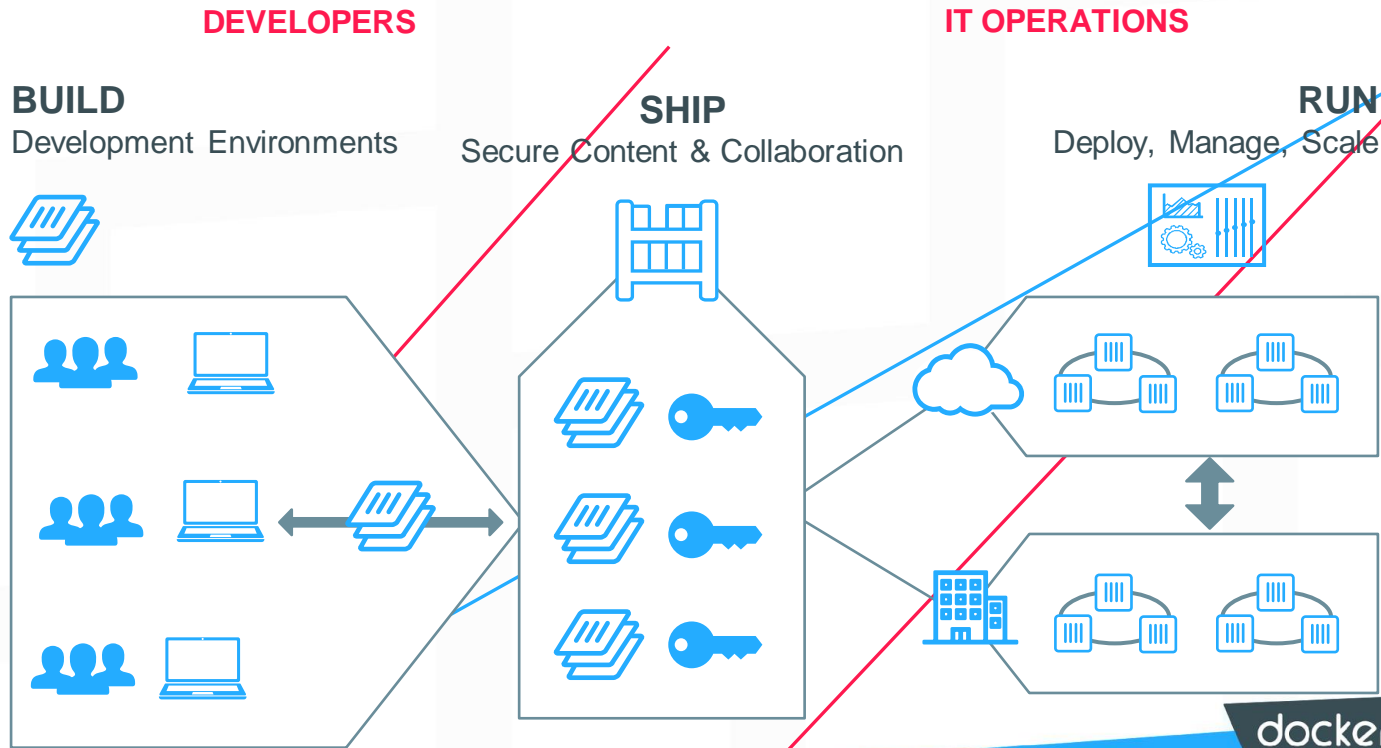

Docker Datacenter Powers CaaS

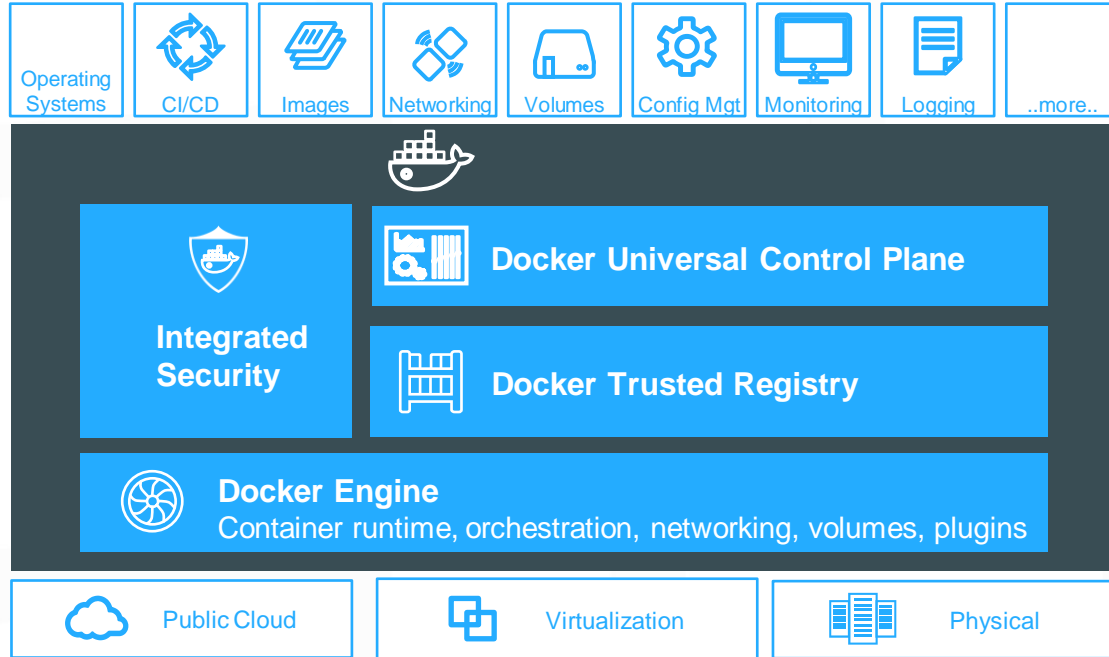

Docker UCP 1.1 - DTR 2.0



- HA
- Unified Auth
- Compose deployment
- UI to add nodes

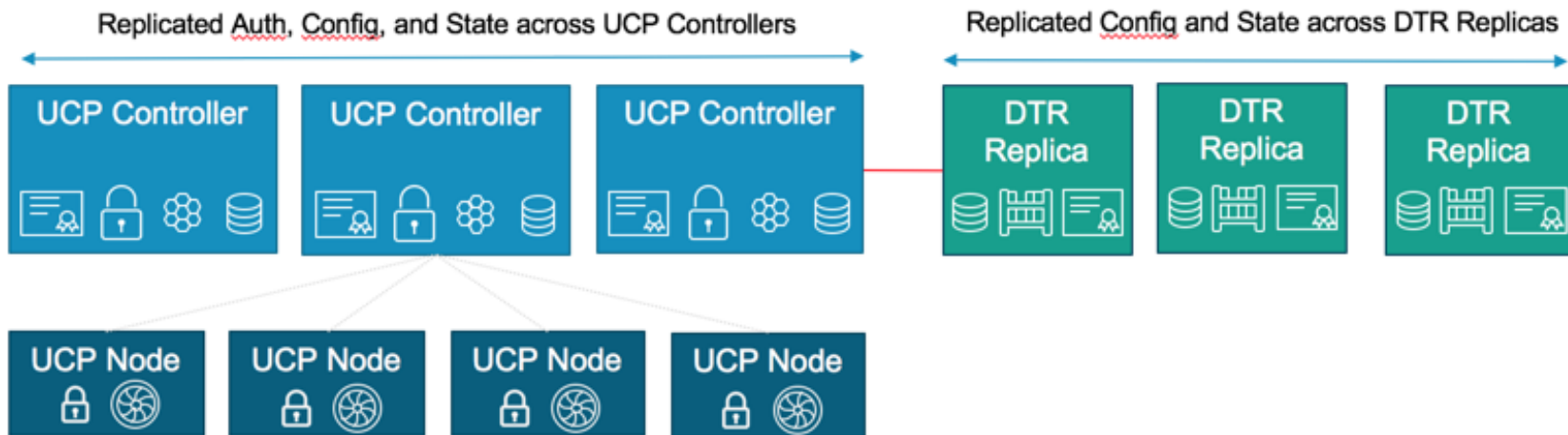

Security scanning in Docker Cloud

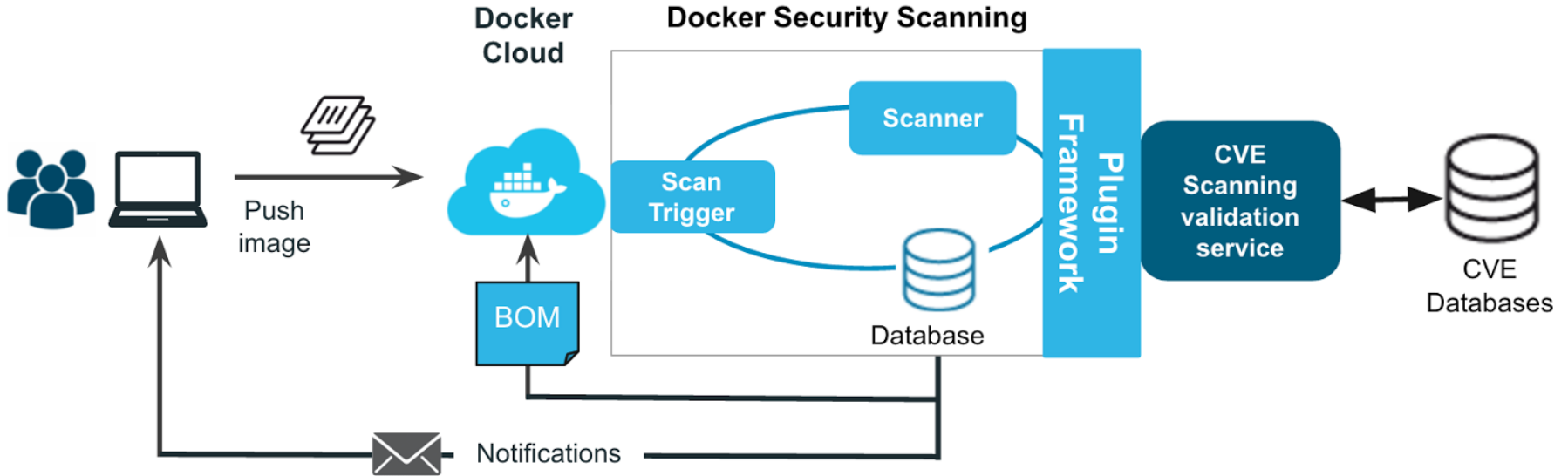

Docker Containers as a Service platform

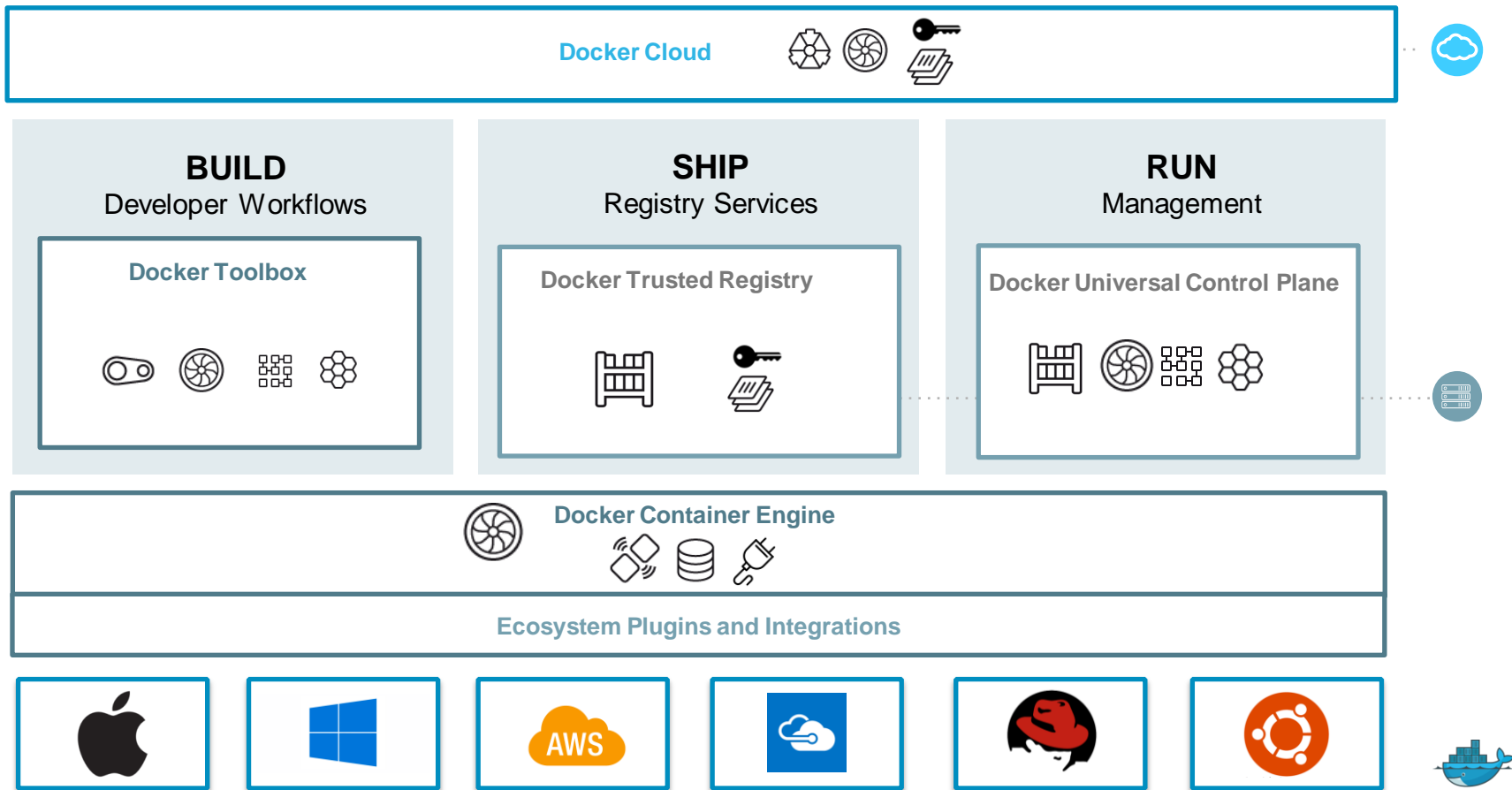

Characteristics of a CaaS

The Power of *AND*

Developers
+ IT Ops

Any
Application
Stage

Any App
Architecture

Any
Language

Any Operating
System

Any
Infrastructure

Open APIs
Broadest Ecosystem Support



Partner Ecosystem

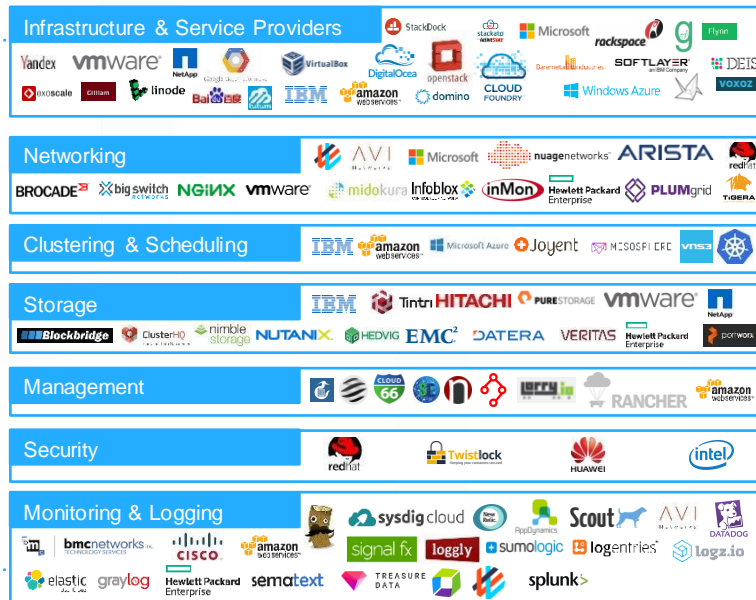
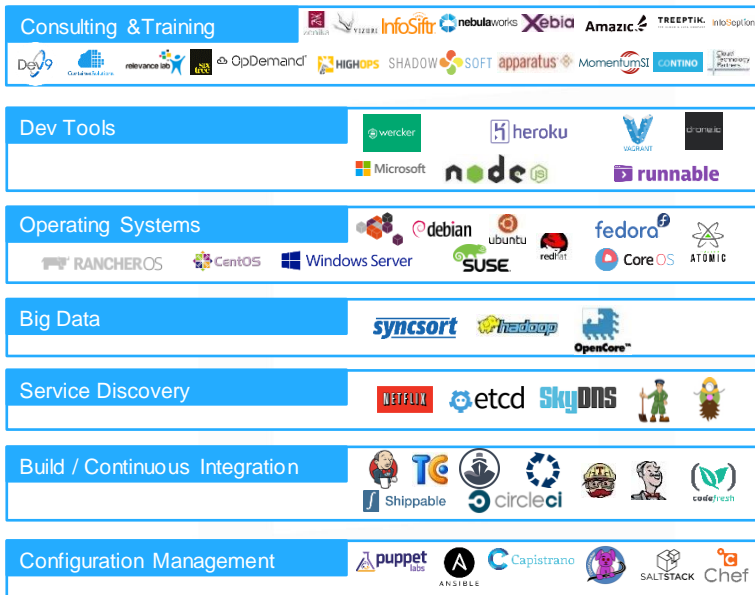

Content is King for Applications



Dockerized Apps
3,000% Growth in 2 years



Official Repos
20% of all image pulls



Growing user demand for
commercial, supported and
licensed content

Docker Store

The marketplace for validated software and tools available in Docker format for businesses and publishers

- **Easy search and deploy**
- **Trusted and compliant**
- **<https://store.docker.com>**

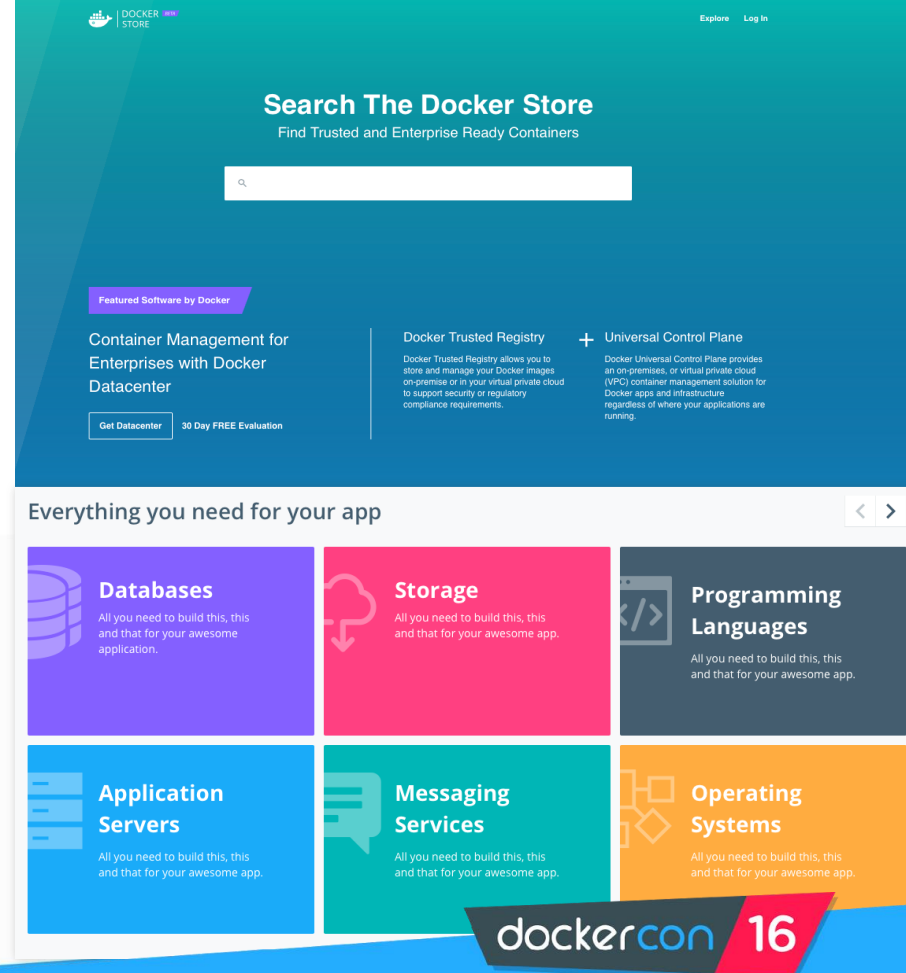

The screenshot shows the Docker Store homepage. At the top left is the Docker Store logo. In the top right corner, there are links for "Explore" and "Log In". The main heading is "Search The Docker Store" with the subtitle "Find Trusted and Enterprise Ready Containers". Below this is a search bar. A section titled "Featured Software by Docker" lists two products: "Container Management for Enterprises with Docker Datacenter" (with a "Get Datacenter" button and "30 Day FREE Evaluation" text) and "Docker Trusted Registry" (with a description: "Docker Trusted Registry allows you to store and manage your Docker images on-premise or in your virtual private cloud to support security or regulatory compliance requirements."). To the right of "Docker Trusted Registry" is a plus sign followed by "Universal Control Plane" (with a description: "Docker Universal Control Plane provides an on-premise, or virtual private cloud (VPC) container management solution for Docker apps and infrastructure regardless of where your applications are running."). Below this is a section titled "Everything you need for your app" with navigation arrows. It contains six colored tiles: "Databases" (purple), "Storage" (pink), "Programming Languages" (dark grey), "Application Servers" (blue), "Messaging Services" (teal), and "Operating Systems" (orange). Each tile has an icon and the text "All you need to build this, this and that for your awesome application." At the bottom right is the "dockercon 16" logo.

Docker Store: Calling All Publishers



Docker Use Cases

Docker in Production

Docker users already running in production

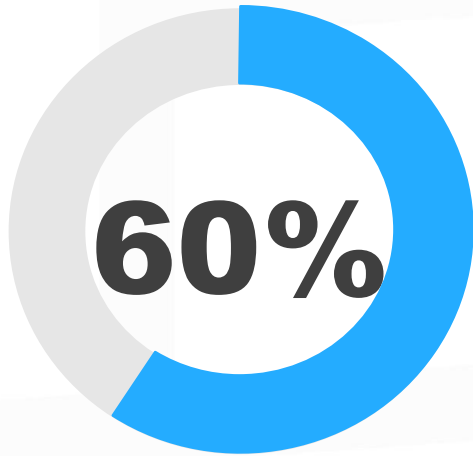

Docker Survey: State of Applications
Q1 2016

Companies running container technology in production
(500+ employees)

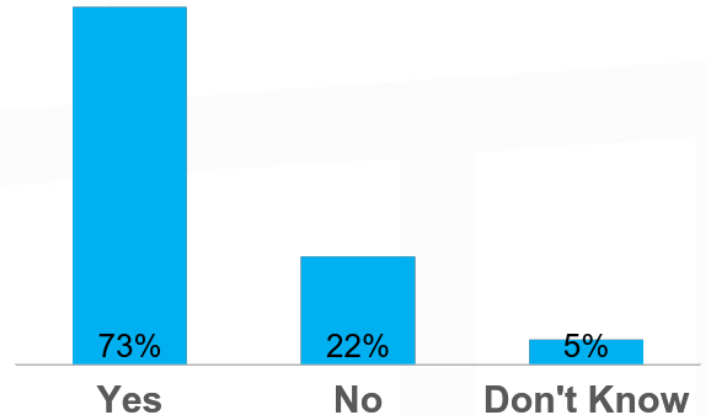

Cluster HQ: State of Container Usage
June 2016

Across the Enterprise

E-commerce / Consumer



Media



Healthcare



Financial Services



Services



Government



Tech



...And More



Docker Enabling Critical Transformations

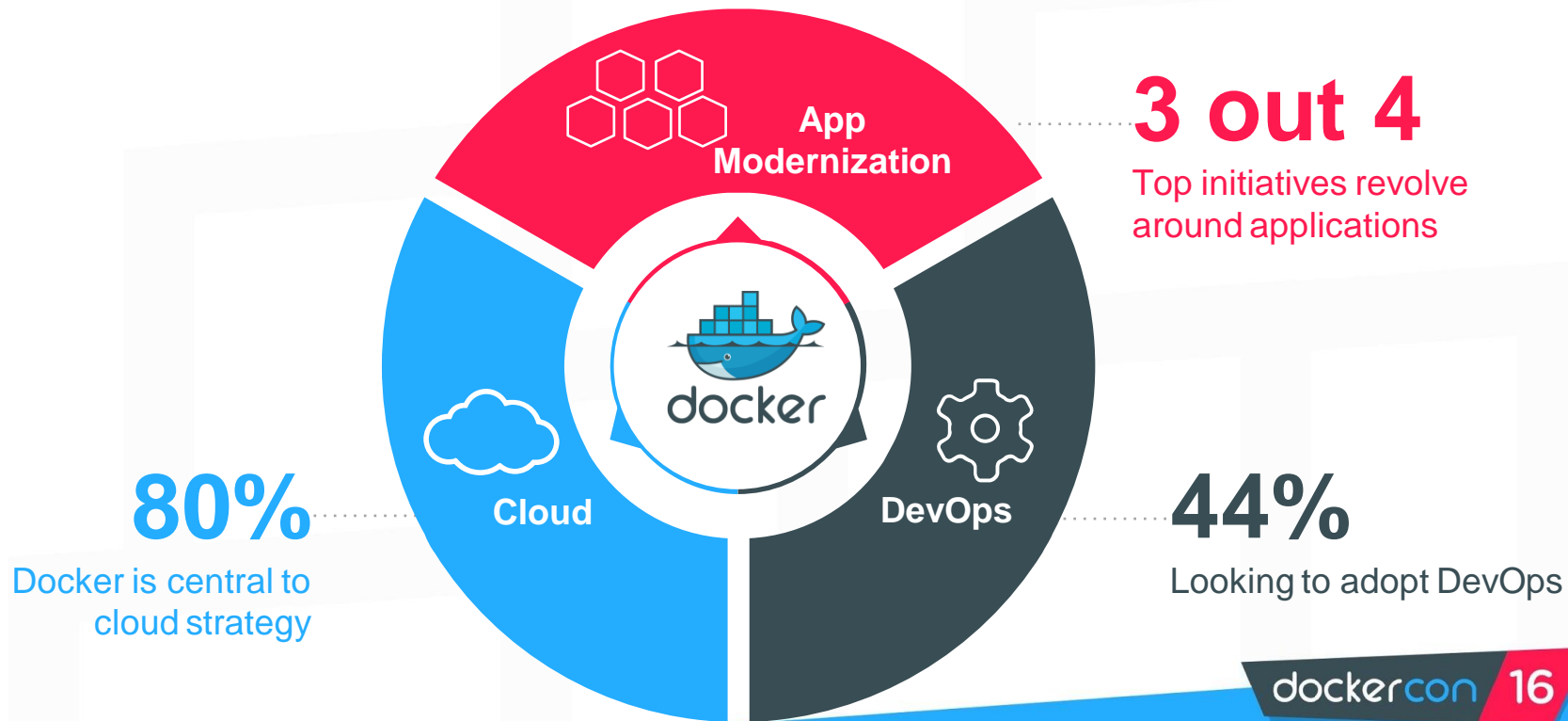

The Data Shows Hybrid Infrastructure and Applications

2016 Docker Use Cases

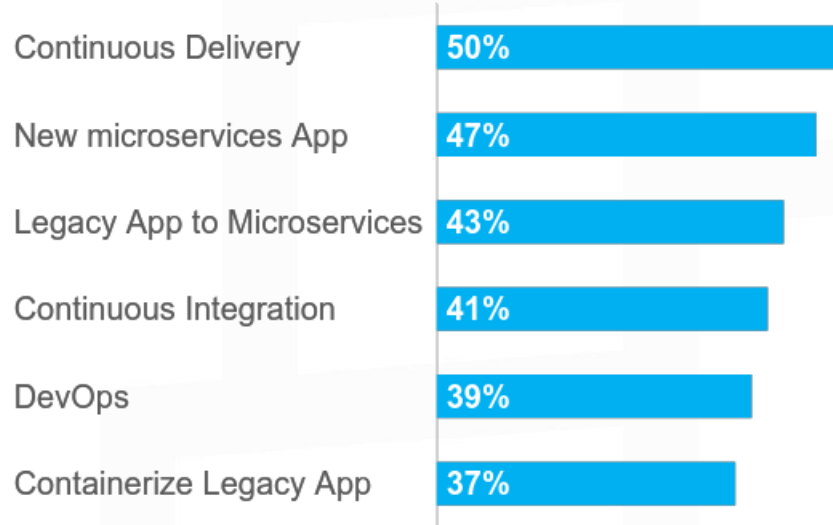

Docker Workloads

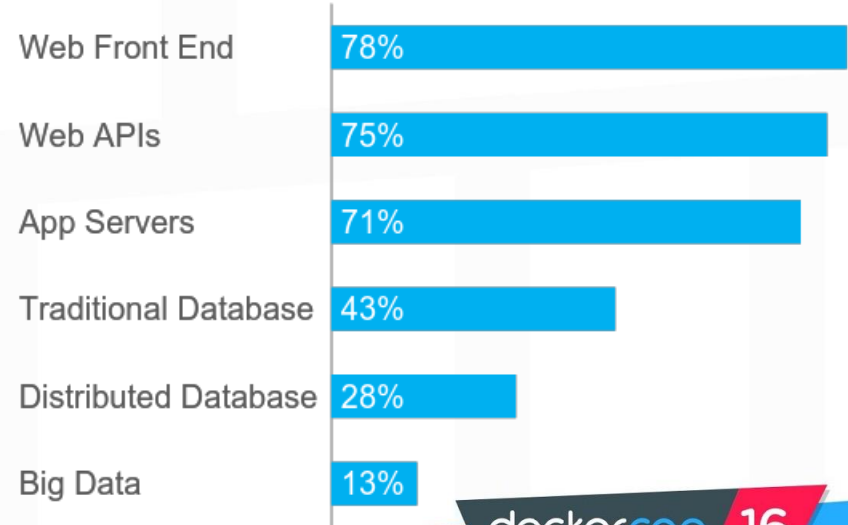



Big Data example: Zenly Analytics

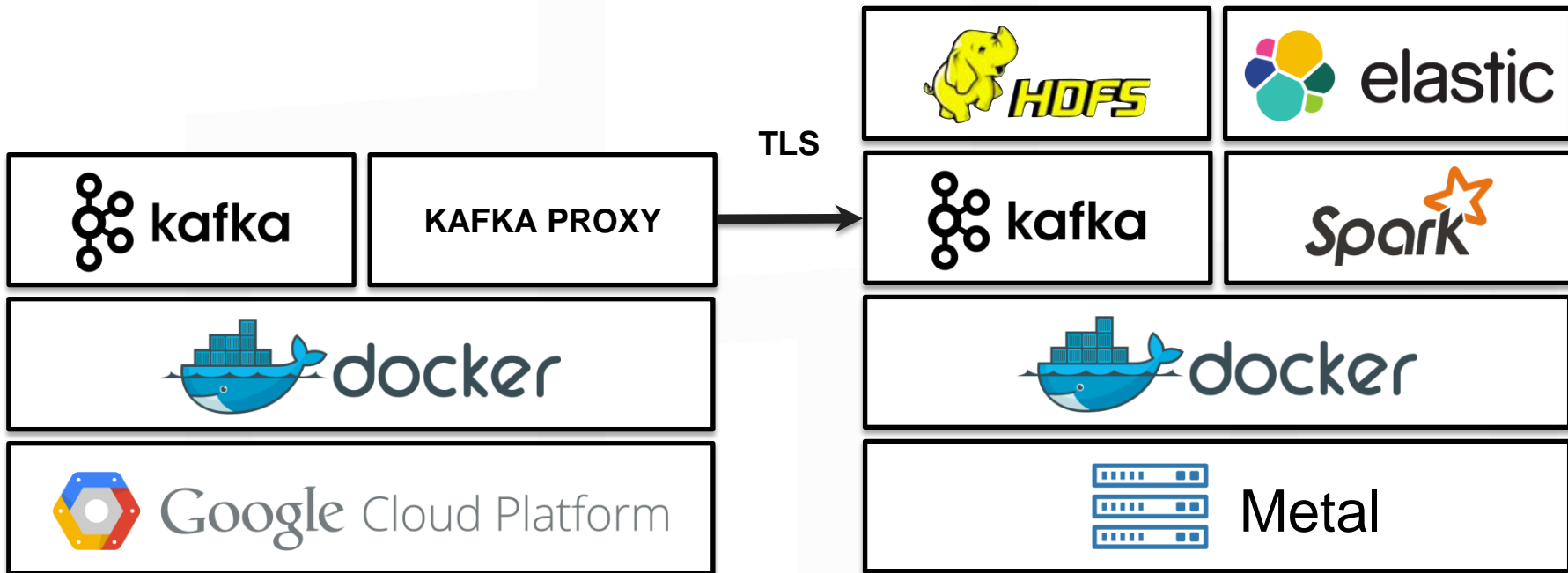

Use Case: Decentralized CaaS for hybrid and multi cloud portability

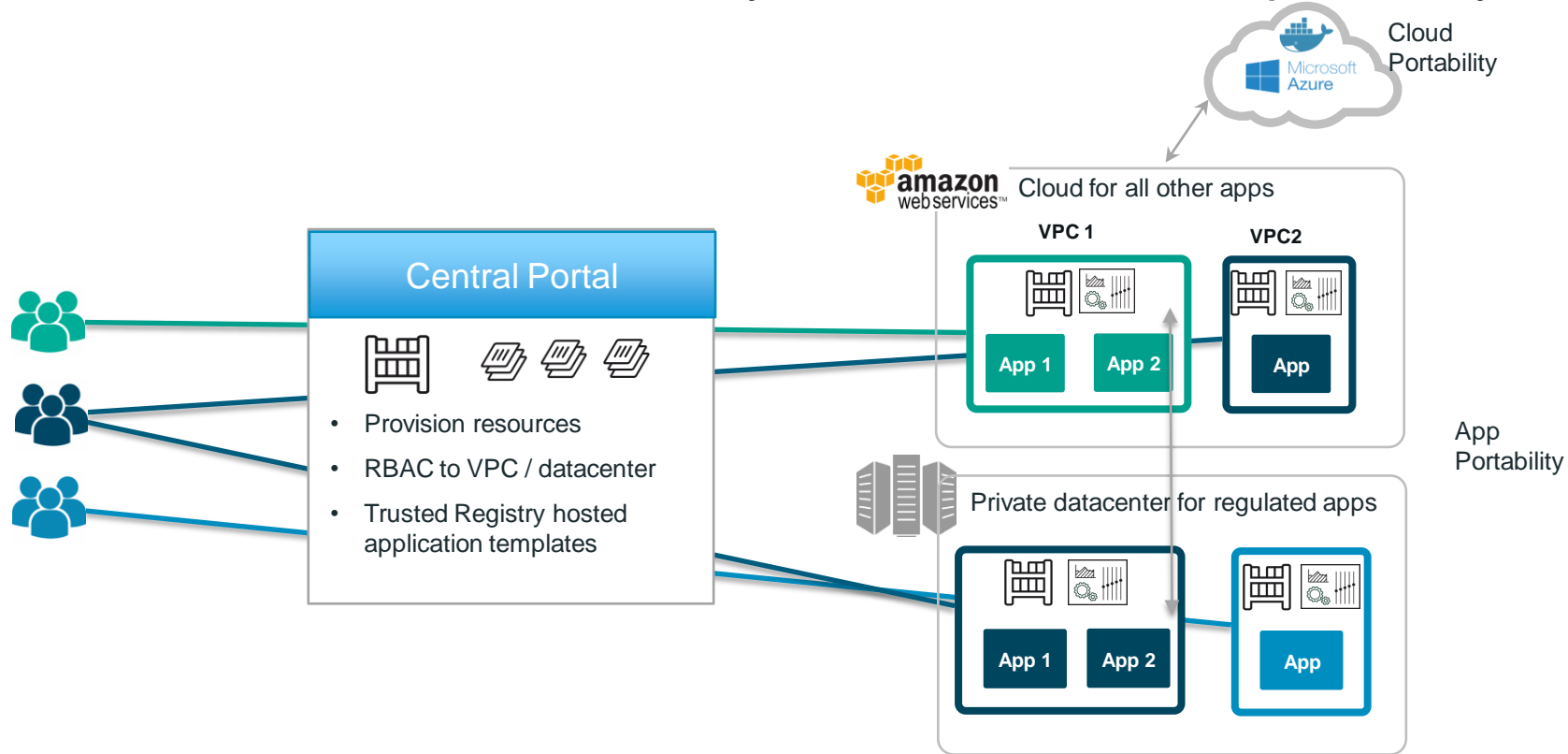

Use Case: Centralized CaaS for transformation to DevOps and micro services

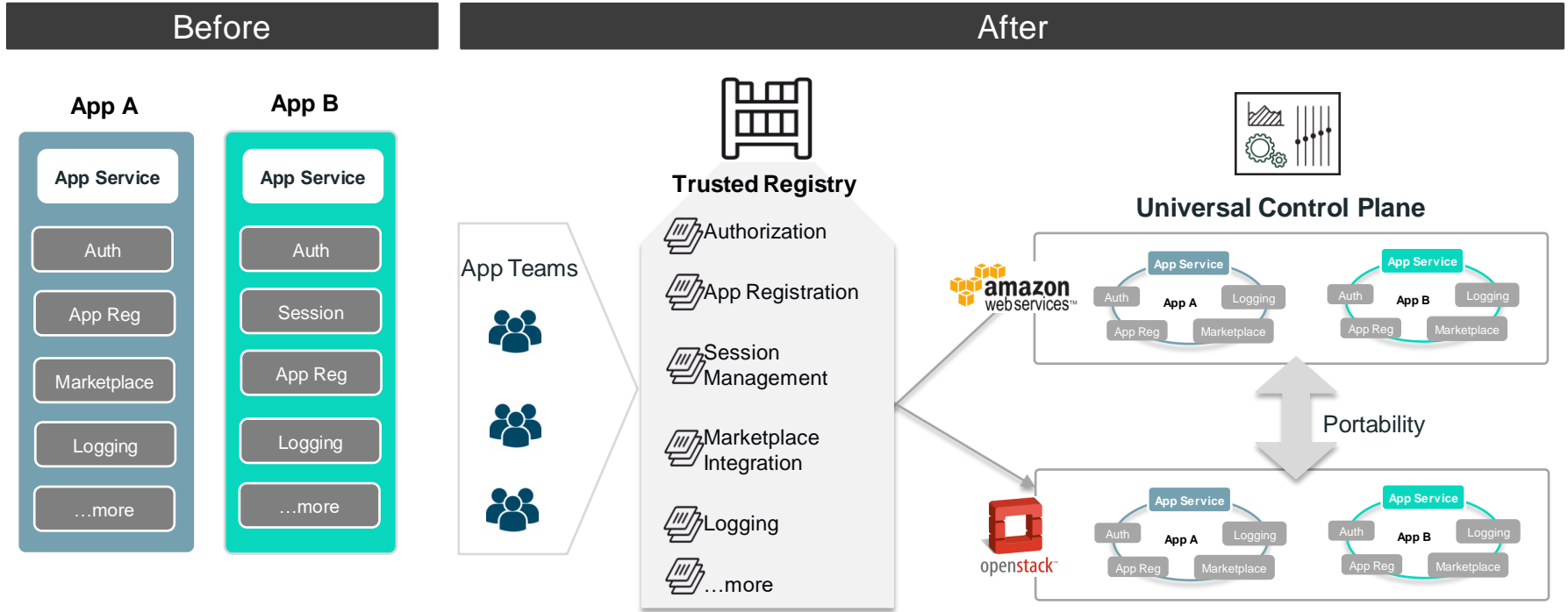

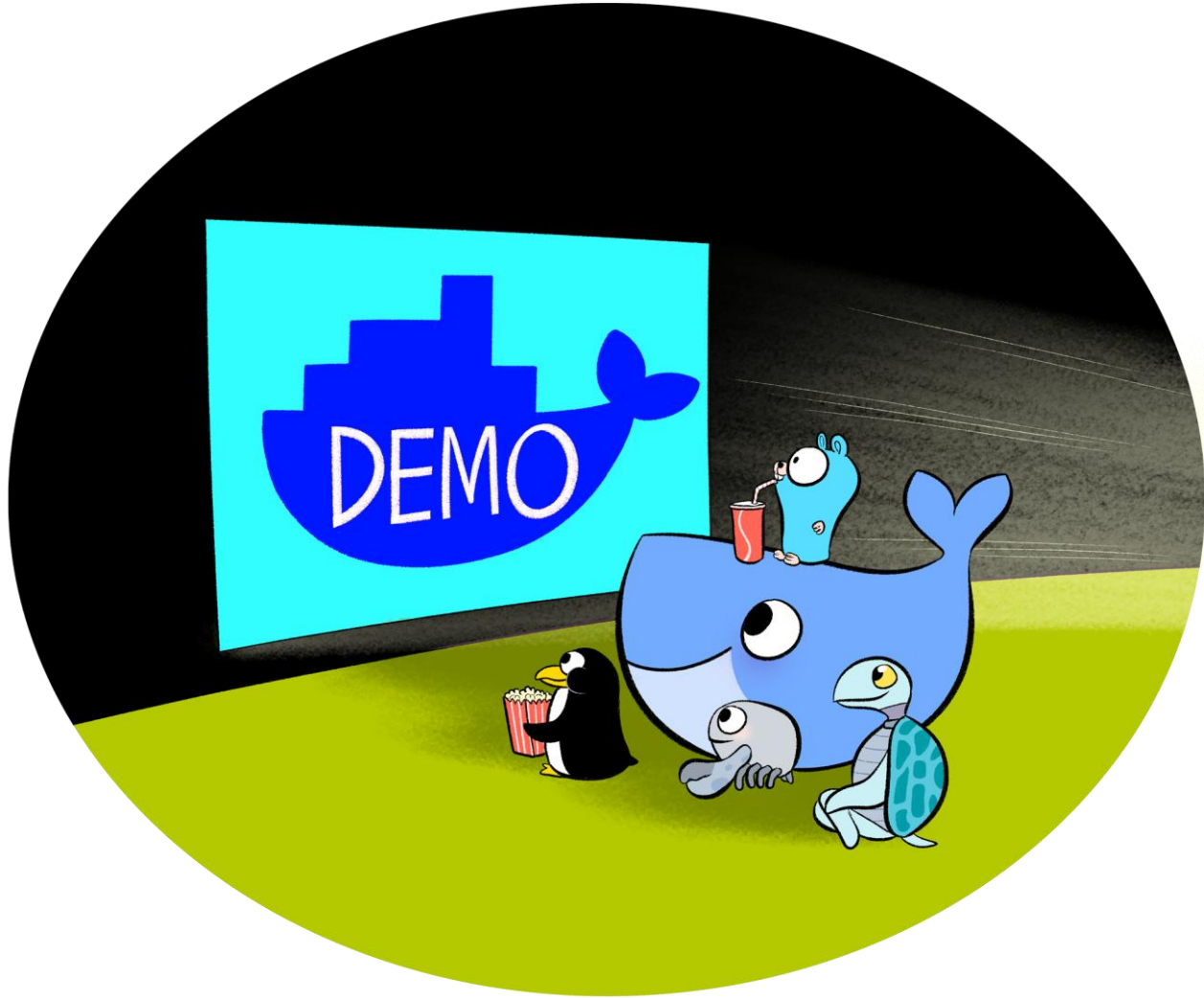

Resources

- Docker
 - docker.com/get-docker
 - beta.docker.com
- Slides
 - <http://www.slideshare.net/chanezon>
 - <http://www.slideshare.net/docker>
- Questions
 - @chanezon
- Code for demos
 - <https://github.com/chanezon/docker-tips>
 - <https://github.com/chanezon/spring-doge>



THANK YOU

Demos

Linux X11 Apps on Docker for Mac

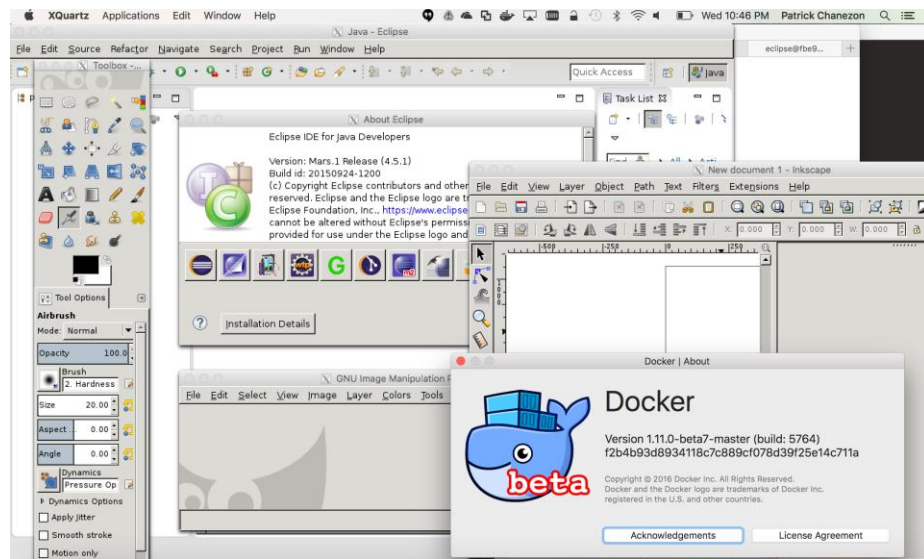
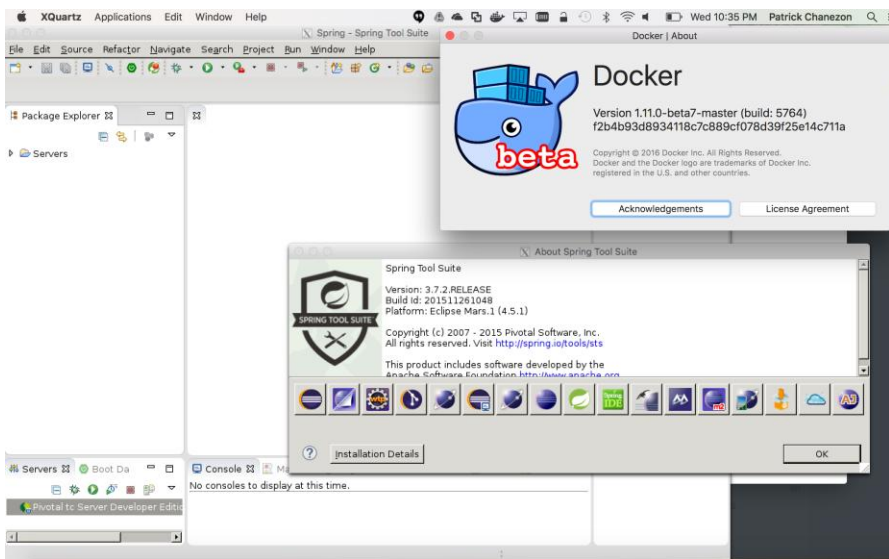

<https://github.com/chanezon/docker-tips/x11>

Spring Boot App using MongoDB

- Docker Swarm, Compose and networking
- docker 1.11
- swarm 1.1.0
- compose 1.6.0 with networking
- Run/Debug with STS IDE in a container



<https://github.com/joshlong/spring-doge>

<https://github.com/chanezon/spring-doge>

<https://github.com/chanezon/docker-tips/orchestration-networking>

Docker Universal Control Plane

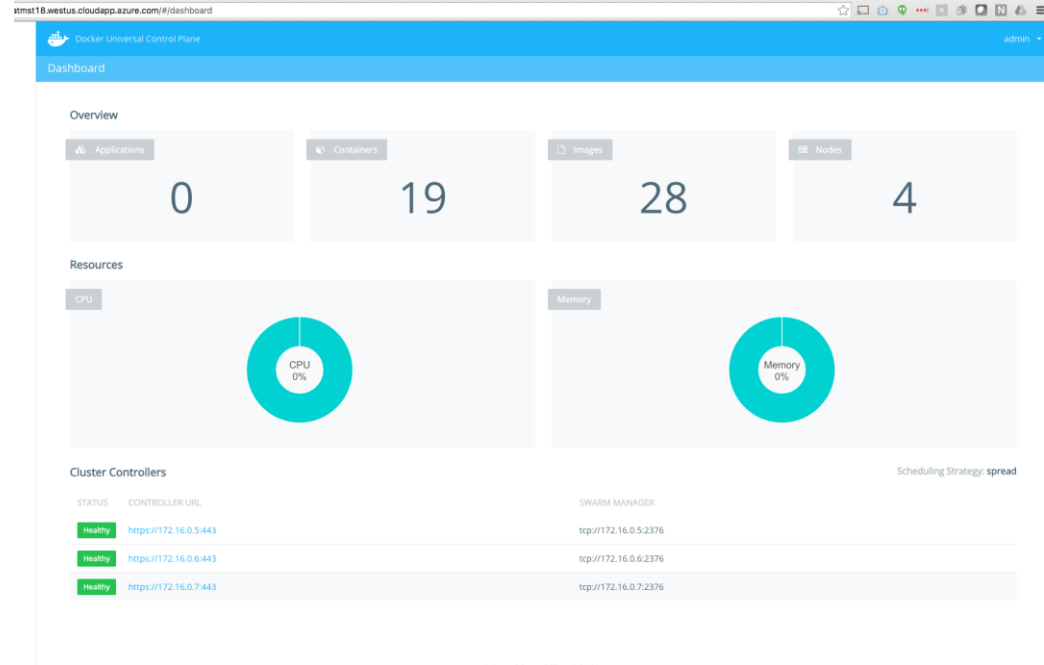
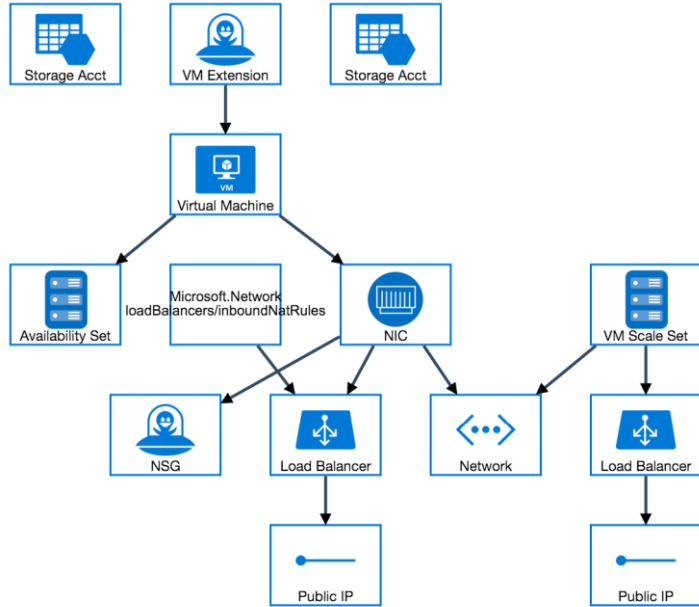

<https://github.com/chanezon/docker-tips/tree/master/azure-acs-ucp>

Load balancing in UCP with Interlock

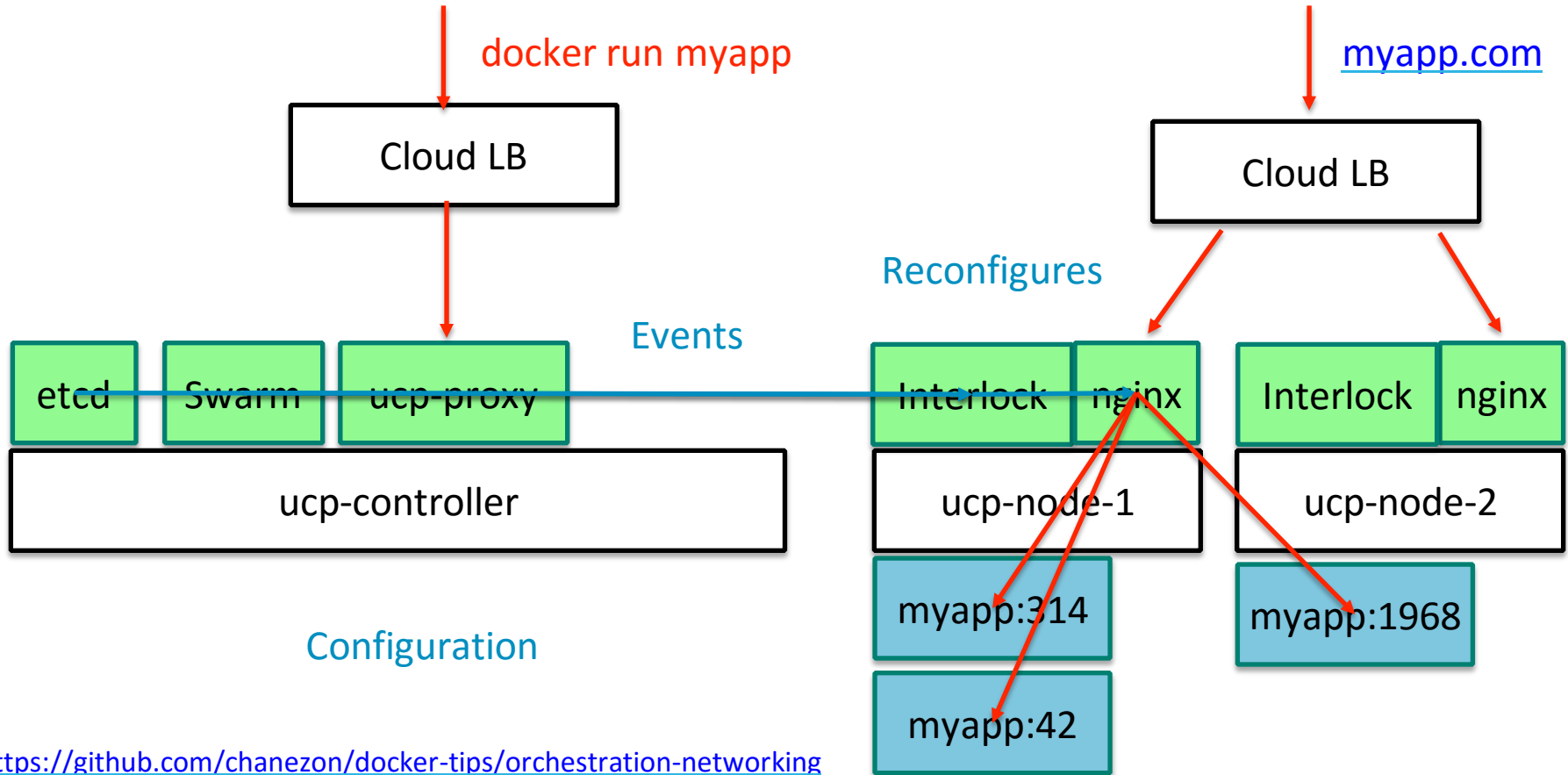

Let's Dockerize a Neo4J App

```
FROM java:8
MAINTAINER Patrick Chanezon <patrick@chanezon.com>
EXPOSE 8080
COPY target/*.jar /usr/src/movie/movie.jar
WORKDIR /usr/src/movie
CMD java -Dserver.port=8080 -jar movie.jar
```

```
web:
  image: chanezon/movies-neo4j
  ports:
    - "80:8080"
  links:
    - neo4j
  environment:
    - NEO4J_URL=http://neo4j:passw0rd@neo4j:7474
neo4j:
  image: neo4j
  volumes:
    - /Users/pat/neo4j-data:/data
  ports:
    - "7474:7474"
```

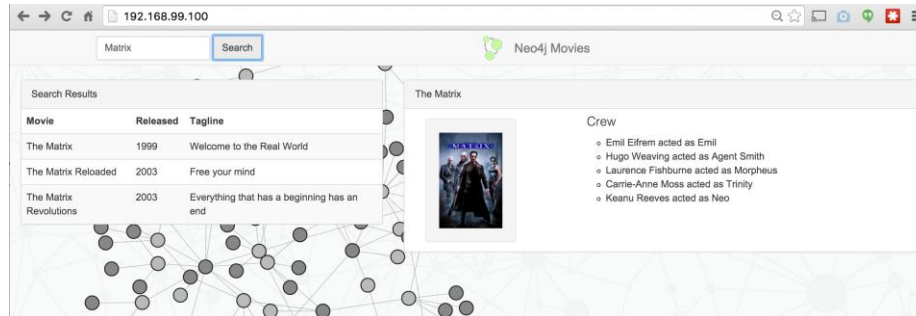

<https://github.com/neo4j-examples/movies-java-spring-data-neo4j-4>

Load balancing in UCP with Interlock

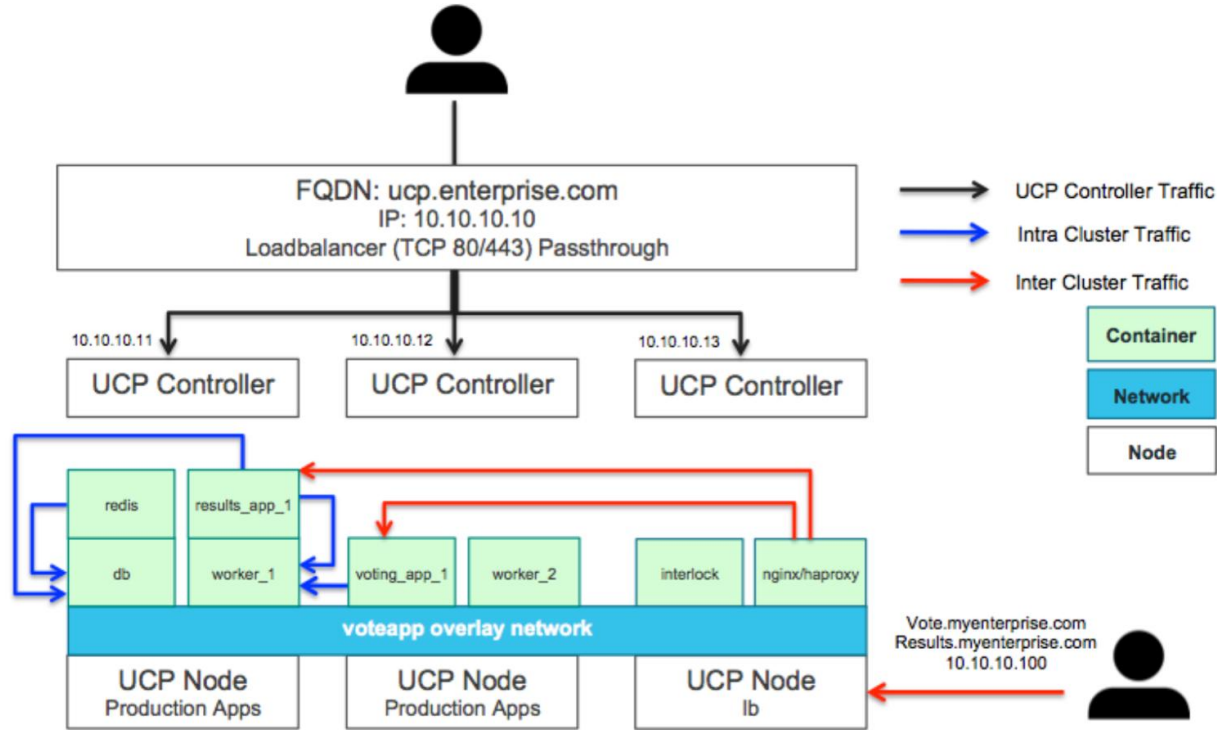

See "Reference Architecture: Service Discovery and Load Balancing with Docker Universal Control Plane (UCP)"

Orchestration projects

- Service Discovery
 - <https://github.com/gliderlabs/registrator>
 - <https://github.com/hashicorp/consul-template>
 - <https://github.com/ehazlett/interlock>
- Persistent volumes with Swarm and Rex Ray on AWS
 - <http://blog.emccode.com/2015/11/03/use-docker-swarm-with-a-data-persistence-layer/>
 - <https://github.com/emccode/rexray>
- Kubernetes on Swarm
 - <https://github.com/docker/swarm-frontends>

Load Balancing

- IPVS, Andrey Sibiryov, <http://www.slideshare.net/Docker/kernel-load-balancing-for-docker-containers-using-ipvs>
- DNS Service Discovery for Docker Swarm, Ahmet Alp Balkan, <http://www.slideshare.net/Docker/dns-service-discovery-for-docker-swarm>

Java Examples

- Spring Boot, MongoDB, compose, swarm, networking
 - <https://github.com/joshlong/spring-doge>
 - <https://github.com/chanezon/docker-tips/orchestration-networking>
- Java EE 7 / Angular App with Docker Swarm by @mgreau
Compose for build and deploy, Wildfly, Apache, Angular, Mysql, Redis, batch and API apps
 - <https://github.com/mgreau/docker4dev-tennistour-app>
- Java EE Docker & Kubernetes by @arun-gupta
 - <https://github.com/javaee-samples/docker-java>

Docker networking

- Docs
<https://docs.docker.com/engine/userguide/networking/dockernetworks/>
- Create a Swarm cluster with networking
<https://github.com/chanezon/docker-tips/orchestration-networking>
- Networking in compose
<https://github.com/docker/compose/blob/master/docs/networking.md>
- Nathan Leclaire Seamless Docker Multihost Overlay Networking on DigitalOcean With Machine, Swarm, and Compose, RethinkDB <http://nathanleclaire.com/blog/2015/11/17/seamless->

Nathan's tips

- Using Ansible with Docker Machine to Bootstrap Host Nodes
<http://nathanleclaire.com/blog/2015/11/10/using-ansible-with-docker-machine-to-bootstrap-host-nodes/>
- Seamless Docker Multihost Overlay Networking on DigitalOcean With Machine, Swarm, and Compose, RethinkDB
<http://nathanleclaire.com/blog/2015/11/17/seamless-docker-multihost-overlay-networking-on-digitalocean-with-machine-swarm-and-compose-ft.-rethinkdb/>

UCP Permission Model

